

# 15

## Multiple Integrals



Geologists study how mountain ranges were formed and estimate the work required to lift them from sea level. In Section 15.8 you are asked to use a triple integral to compute the work done in the formation of Mount Fuji in Japan.

© S.R. Lee Photo Traveller / Shutterstock

In this chapter we extend the idea of a definite integral to double and triple integrals of functions of two or three variables. These ideas are then used to compute volumes, masses, and centroids of more general regions than we were able to consider in Chapters 6 and 8. We also use double integrals to calculate probabilities when two random variables are involved.

We will see that polar coordinates are useful in computing double integrals over some types of regions. In a similar way, we will introduce two new coordinate systems in three-dimensional space—cylindrical coordinates and spherical coordinates—that greatly simplify the computation of triple integrals over certain commonly occurring solid regions.

## 15.1 Double Integrals over Rectangles

In much the same way that our attempt to solve the area problem led to the definition of a definite integral, we now seek to find the volume of a solid and in the process we arrive at the definition of a double integral.

### Review of the Definite Integral

First let's recall the basic facts concerning definite integrals of functions of a single variable. If  $f(x)$  is defined for  $a \leq x \leq b$ , we start by dividing the interval  $[a, b]$  into  $n$  subintervals  $[x_{i-1}, x_i]$  of equal width  $\Delta x = (b - a)/n$  and we choose sample points  $x_i^*$  in these subintervals. Then we form the Riemann sum

$$\boxed{1} \quad \sum_{i=1}^n f(x_i^*) \Delta x$$

and take the limit of such sums as  $n \rightarrow \infty$  to obtain the definite integral of  $f$  from  $a$  to  $b$ :

$$\boxed{2} \quad \int_a^b f(x) dx = \lim_{n \rightarrow \infty} \sum_{i=1}^n f(x_i^*) \Delta x$$

In the special case where  $f(x) \geq 0$ , the Riemann sum can be interpreted as the sum of the areas of the approximating rectangles in Figure 1, and  $\int_a^b f(x) dx$  represents the area under the curve  $y = f(x)$  from  $a$  to  $b$ .

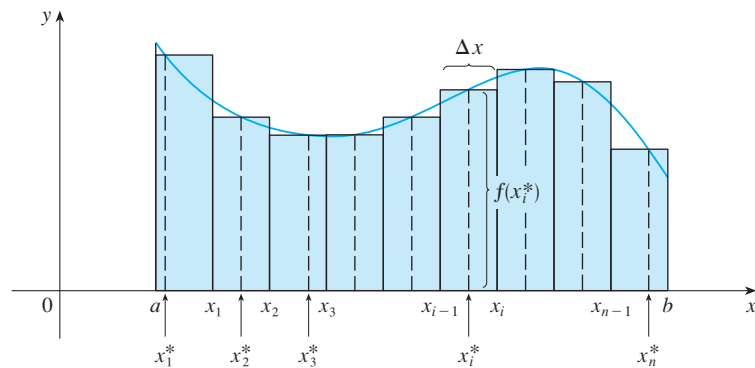


FIGURE 1

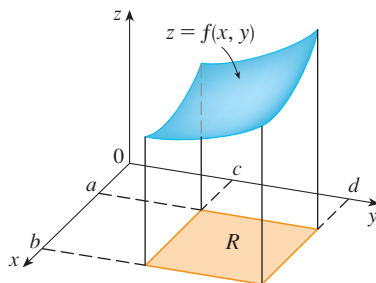


FIGURE 2

### Volumes and Double Integrals

In a similar manner we consider a function  $f$  of two variables defined on a closed rectangle

$$R = [a, b] \times [c, d] = \{(x, y) \in \mathbb{R}^2 \mid a \leq x \leq b, c \leq y \leq d\}$$

and we first suppose that  $f(x, y) \geq 0$ . The graph of  $f$  is a surface with equation  $z = f(x, y)$ . Let  $S$  be the solid that lies above  $R$  and under the graph of  $f$ , that is,

$$S = \{(x, y, z) \in \mathbb{R}^3 \mid 0 \leq z \leq f(x, y), (x, y) \in R\}$$

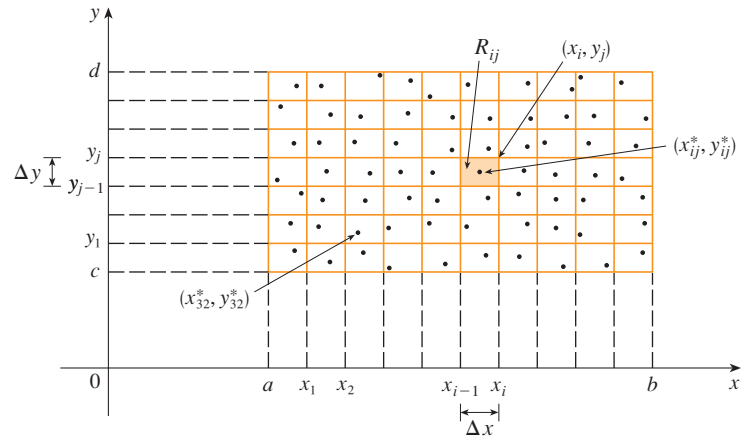
(See Figure 2.) Our goal is to find the volume of  $S$ .

The first step is to divide the rectangle  $R$  into subrectangles. We accomplish this by dividing the interval  $[a, b]$  into  $m$  subintervals  $[x_{i-1}, x_i]$  of equal width  $\Delta x = (b - a)/m$  and dividing  $[c, d]$  into  $n$  subintervals  $[y_{j-1}, y_j]$  of equal width  $\Delta y = (d - c)/n$ . By drawing lines parallel to the coordinate axes through the endpoints of these subintervals, as in

Figure 3, we form the subrectangles

$$R_{ij} = [x_{i-1}, x_i] \times [y_{j-1}, y_j] = \{(x, y) \mid x_{i-1} \leq x \leq x_i, y_{j-1} \leq y \leq y_j\}$$

each with area  $\Delta A = \Delta x \Delta y$ .



**FIGURE 3**  
Dividing  $R$  into subrectangles

If we choose a **sample point**  $(x_{ij}^*, y_{ij}^*)$  in each  $R_{ij}$ , then we can approximate the part of  $S$  that lies above each  $R_{ij}$  by a thin rectangular box (or “column”) with base  $R_{ij}$  and height  $f(x_{ij}^*, y_{ij}^*)$  as shown in Figure 4. (Compare with Figure 1.) The volume of this box is the height of the box times the area of the base rectangle:

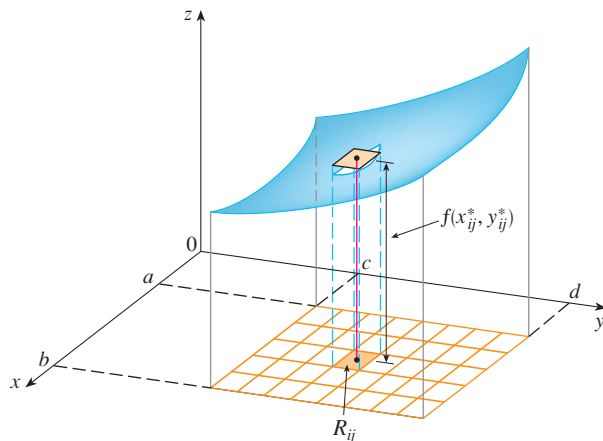
$$f(x_{ij}^*, y_{ij}^*) \Delta A$$

If we follow this procedure for all the rectangles and add the volumes of the corresponding boxes, we get an approximation to the total volume of  $S$ :

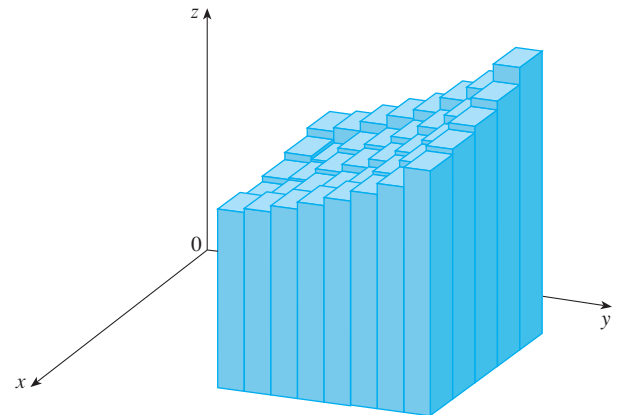
**3**

$$V \approx \sum_{i=1}^m \sum_{j=1}^n f(x_{ij}^*, y_{ij}^*) \Delta A$$

(See Figure 5.) This double sum means that for each subrectangle we evaluate  $f$  at the chosen point and multiply by the area of the subrectangle, and then we add the results.



**FIGURE 4**



**FIGURE 5**

The meaning of the double limit in Equation 4 is that we can make the double sum as close as we like to the number  $V$  [for any choice of  $(x_{ij}^*, y_{ij}^*)$  in  $R_{ij}$ ] by taking  $m$  and  $n$  sufficiently large.

Our intuition tells us that the approximation given in [3] becomes better as  $m$  and  $n$  become larger and so we would expect that

$$4 \quad V = \lim_{m, n \rightarrow \infty} \sum_{i=1}^m \sum_{j=1}^n f(x_{ij}^*, y_{ij}^*) \Delta A$$

We use the expression in Equation 4 to define the **volume** of the solid  $S$  that lies under the graph of  $f$  and above the rectangle  $R$ . (It can be shown that this definition is consistent with our formula for volume in Section 6.2.)

Limits of the type that appear in Equation 4 occur frequently, not just in finding volumes but in a variety of other situations as well—as we will see in Section 15.5—even when  $f$  is not a positive function. So we make the following definition.

**5 Definition** The **double integral** of  $f$  over the rectangle  $R$  is

$$\iint_R f(x, y) \, dA = \lim_{m, n \rightarrow \infty} \sum_{i=1}^m \sum_{j=1}^n f(x_{ij}^*, y_{ij}^*) \Delta A$$

if this limit exists.

Notice the similarity between Definition 5 and the definition of a single integral in Equation 2.

Although we have defined the double integral by dividing  $R$  into equal-sized subrectangles, we could have used subrectangles  $R_{ij}$  of unequal size. But then we would have to ensure that all of their dimensions approach 0 in the limiting process.

The precise meaning of the limit in Definition 5 is that for every number  $\varepsilon > 0$  there is an integer  $N$  such that

$$\left| \iint_R f(x, y) \, dA - \sum_{i=1}^m \sum_{j=1}^n f(x_{ij}^*, y_{ij}^*) \Delta A \right| < \varepsilon$$

for all integers  $m$  and  $n$  greater than  $N$  and for any choice of sample points  $(x_{ij}^*, y_{ij}^*)$  in  $R_{ij}$ .

A function  $f$  is called **integrable** if the limit in Definition 5 exists. It is shown in courses on advanced calculus that all continuous functions are integrable. In fact, the double integral of  $f$  exists provided that  $f$  is “not too discontinuous.” In particular, if  $f$  is bounded [that is, there is a constant  $M$  such that  $|f(x, y)| \leq M$  for all  $(x, y)$  in  $R$ ], and  $f$  is continuous there, except on a finite number of smooth curves, then  $f$  is integrable over  $R$ .

The sample point  $(x_{ij}^*, y_{ij}^*)$  can be chosen to be any point in the subrectangle  $R_{ij}$ , but if we choose it to be the upper right-hand corner of  $R_{ij}$  [namely  $(x_i, y_j)$ , see Figure 3], then the expression for the double integral looks simpler:

$$6 \quad \iint_R f(x, y) \, dA = \lim_{m, n \rightarrow \infty} \sum_{i=1}^m \sum_{j=1}^n f(x_i, y_j) \Delta A$$

By comparing Definitions 4 and 5, we see that a volume can be written as a double integral:

If  $f(x, y) \geq 0$ , then the volume  $V$  of the solid that lies above the rectangle  $R$  and below the surface  $z = f(x, y)$  is

$$V = \iint_R f(x, y) \, dA$$

The sum in Definition 5,

$$\sum_{i=1}^m \sum_{j=1}^n f(x_{ij}^*, y_{ij}^*) \Delta A$$

is called a **double Riemann sum** and is used as an approximation to the value of the double integral. [Notice how similar it is to the Riemann sum in [1](#) for a function of a single variable.] If  $f$  happens to be a *positive* function, then the double Riemann sum represents the sum of volumes of columns, as in Figure 5, and is an approximation to the volume under the graph of  $f$ .

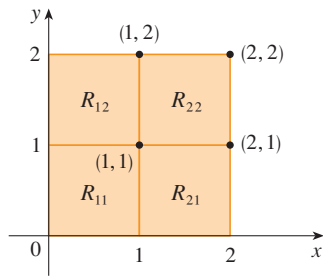


FIGURE 6

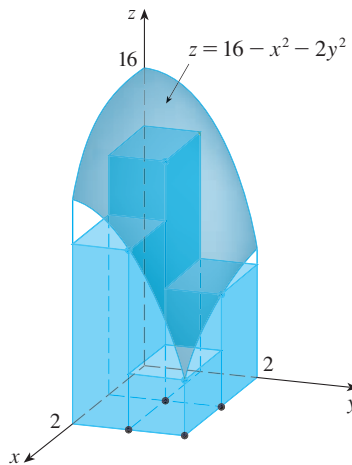
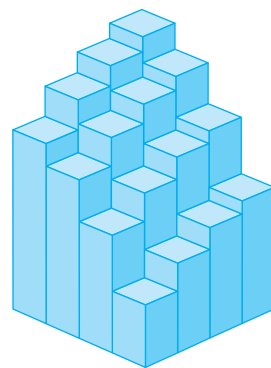
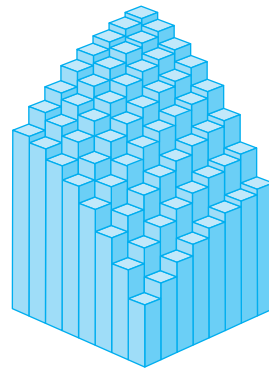


FIGURE 7

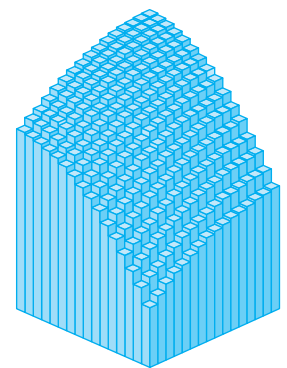
**FIGURE 8**  
The Riemann sum approximations to the volume under  $z = 16 - x^2 - 2y^2$  become more accurate as  $m$  and  $n$  increase.



(a)  $m = n = 4$ ,  $V \approx 41.5$



(b)  $m = n = 8$ ,  $V \approx 44.875$



(c)  $m = n = 16$ ,  $V \approx 46.46875$

**V EXAMPLE 1** Estimate the volume of the solid that lies above the square  $R = [0, 2] \times [0, 2]$  and below the elliptic paraboloid  $z = 16 - x^2 - 2y^2$ . Divide  $R$  into four equal squares and choose the sample point to be the upper right corner of each square  $R_{ij}$ . Sketch the solid and the approximating rectangular boxes.

**SOLUTION** The squares are shown in Figure 6. The paraboloid is the graph of  $f(x, y) = 16 - x^2 - 2y^2$  and the area of each square is  $\Delta A = 1$ . Approximating the volume by the Riemann sum with  $m = n = 2$ , we have

$$\begin{aligned} V &\approx \sum_{i=1}^2 \sum_{j=1}^2 f(x_i, y_j) \Delta A \\ &= f(1, 1) \Delta A + f(1, 2) \Delta A + f(2, 1) \Delta A + f(2, 2) \Delta A \\ &= 13(1) + 7(1) + 10(1) + 4(1) = 34 \end{aligned}$$

This is the volume of the approximating rectangular boxes shown in Figure 7.

We get better approximations to the volume in Example 1 if we increase the number of squares. Figure 8 shows how the columns start to look more like the actual solid and the corresponding approximations become more accurate when we use 16, 64, and 256 squares. In the next section we will be able to show that the exact volume is 48.

**V EXAMPLE 2** If  $R = \{(x, y) \mid -1 \leq x \leq 1, -2 \leq y \leq 2\}$ , evaluate the integral

$$\iint_R \sqrt{1 - x^2} \, dA$$

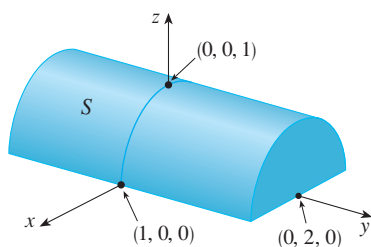


FIGURE 9

**SOLUTION** It would be very difficult to evaluate this integral directly from Definition 5 but, because  $\sqrt{1-x^2} \geq 0$ , we can compute the integral by interpreting it as a volume. If  $z = \sqrt{1-x^2}$ , then  $x^2 + z^2 = 1$  and  $z \geq 0$ , so the given double integral represents the volume of the solid  $S$  that lies below the circular cylinder  $x^2 + z^2 = 1$  and above the rectangle  $R$ . (See Figure 9.) The volume of  $S$  is the area of a semicircle with radius 1 times the length of the cylinder. Thus

$$\iint_R \sqrt{1-x^2} \, dA = \frac{1}{2} \pi (1)^2 \times 4 = 2\pi$$

### The Midpoint Rule

The methods that we used for approximating single integrals (the Midpoint Rule, the Trapezoidal Rule, Simpson's Rule) all have counterparts for double integrals. Here we consider only the Midpoint Rule for double integrals. This means that we use a double Riemann sum to approximate the double integral, where the sample point  $(x_{ij}^*, y_{ij}^*)$  in  $R_{ij}$  is chosen to be the center  $(\bar{x}_i, \bar{y}_j)$  of  $R_{ij}$ . In other words,  $\bar{x}_i$  is the midpoint of  $[x_{i-1}, x_i]$  and  $\bar{y}_j$  is the midpoint of  $[y_{j-1}, y_j]$ .

#### Midpoint Rule for Double Integrals

$$\iint_R f(x, y) \, dA \approx \sum_{i=1}^m \sum_{j=1}^n f(\bar{x}_i, \bar{y}_j) \Delta A$$

where  $\bar{x}_i$  is the midpoint of  $[x_{i-1}, x_i]$  and  $\bar{y}_j$  is the midpoint of  $[y_{j-1}, y_j]$ .

**V EXAMPLE 3** Use the Midpoint Rule with  $m = n = 2$  to estimate the value of the integral  $\iint_R (x - 3y^2) \, dA$ , where  $R = \{(x, y) \mid 0 \leq x \leq 2, 1 \leq y \leq 2\}$ .

**SOLUTION** In using the Midpoint Rule with  $m = n = 2$ , we evaluate  $f(x, y) = x - 3y^2$  at the centers of the four subrectangles shown in Figure 10. So  $\bar{x}_1 = \frac{1}{2}$ ,  $\bar{x}_2 = \frac{3}{2}$ ,  $\bar{y}_1 = \frac{5}{4}$ , and  $\bar{y}_2 = \frac{7}{4}$ . The area of each subrectangle is  $\Delta A = \frac{1}{2}$ . Thus

$$\begin{aligned} \iint_R (x - 3y^2) \, dA &\approx \sum_{i=1}^2 \sum_{j=1}^2 f(\bar{x}_i, \bar{y}_j) \Delta A \\ &= f(\bar{x}_1, \bar{y}_1) \Delta A + f(\bar{x}_1, \bar{y}_2) \Delta A + f(\bar{x}_2, \bar{y}_1) \Delta A + f(\bar{x}_2, \bar{y}_2) \Delta A \\ &= f\left(\frac{1}{2}, \frac{5}{4}\right) \Delta A + f\left(\frac{1}{2}, \frac{7}{4}\right) \Delta A + f\left(\frac{3}{2}, \frac{5}{4}\right) \Delta A + f\left(\frac{3}{2}, \frac{7}{4}\right) \Delta A \\ &= \left(-\frac{67}{16}\right) \frac{1}{2} + \left(-\frac{139}{16}\right) \frac{1}{2} + \left(-\frac{51}{16}\right) \frac{1}{2} + \left(-\frac{123}{16}\right) \frac{1}{2} \\ &= -\frac{95}{8} = -11.875 \end{aligned}$$

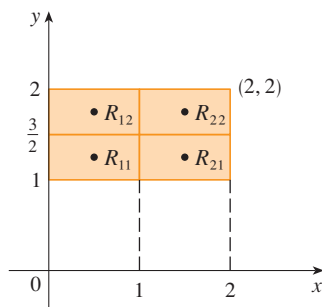


FIGURE 10

Thus we have

$$\iint_R (x - 3y^2) \, dA \approx -11.875$$

**NOTE** In the next section we will develop an efficient method for computing double integrals and then we will see that the exact value of the double integral in Example 3 is  $-12$ . (Remember that the interpretation of a double integral as a volume is valid only when the integrand  $f$  is a *positive* function. The integrand in Example 3 is not a positive function, so its integral is not a volume. In Examples 2 and 3 in Section 15.2 we will discuss how to interpret integrals of functions that are not always positive in terms of volumes.) If we keep dividing each subrectangle in Figure 10 into four smaller ones with similar shape,

Number of subrectangles	Midpoint Rule approximation
1	-11.5000
4	-11.8750
16	-11.9687
64	-11.9922
256	-11.9980
1024	-11.9995

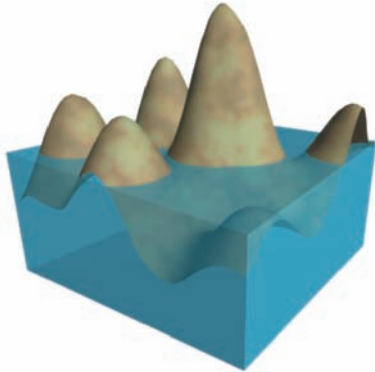


FIGURE 11

we get the Midpoint Rule approximations displayed in the chart in the margin. Notice how these approximations approach the exact value of the double integral,  $-12$ .

### Average Value

Recall from Section 6.5 that the average value of a function  $f$  of one variable defined on an interval  $[a, b]$  is

$$f_{\text{ave}} = \frac{1}{b-a} \int_a^b f(x) dx$$

In a similar fashion we define the **average value** of a function  $f$  of two variables defined on a rectangle  $R$  to be

$$f_{\text{ave}} = \frac{1}{A(R)} \iint_R f(x, y) dA$$

where  $A(R)$  is the area of  $R$ .

If  $f(x, y) \geq 0$ , the equation

$$A(R) \times f_{\text{ave}} = \iint_R f(x, y) dA$$

says that the box with base  $R$  and height  $f_{\text{ave}}$  has the same volume as the solid that lies under the graph of  $f$ . [If  $z = f(x, y)$  describes a mountainous region and you chop off the tops of the mountains at height  $f_{\text{ave}}$ , then you can use them to fill in the valleys so that the region becomes completely flat. See Figure 11.]

**EXAMPLE 4** The contour map in Figure 12 shows the snowfall, in inches, that fell on the state of Colorado on December 20 and 21, 2006. (The state is in the shape of a rectangle that measures 388 mi west to east and 276 mi south to north.) Use the contour map to estimate the average snowfall for the entire state of Colorado on those days.

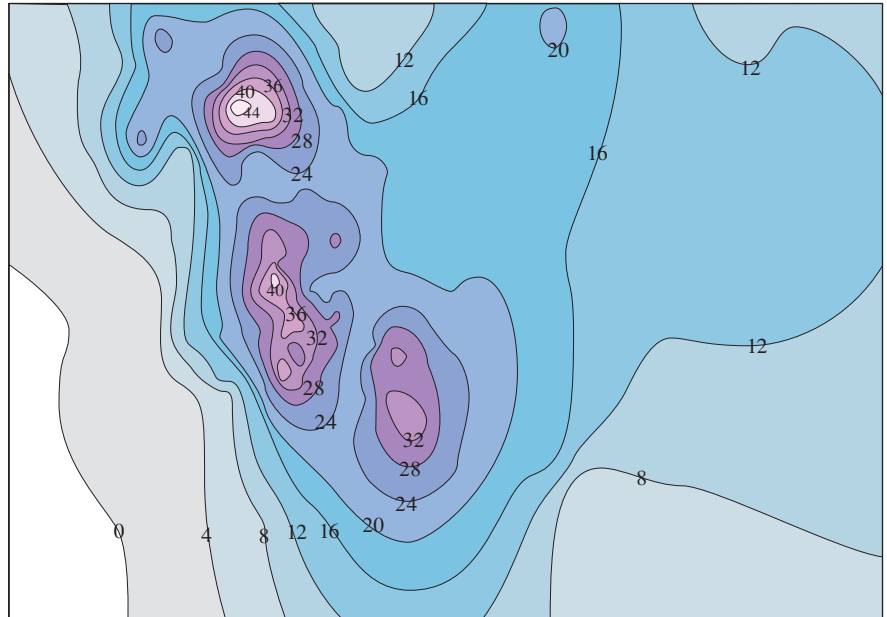


FIGURE 12

**SOLUTION** Let's place the origin at the southwest corner of the state. Then  $0 \leq x \leq 388$ ,  $0 \leq y \leq 276$ , and  $f(x, y)$  is the snowfall, in inches, at a location  $x$  miles to the east and

$y$  miles to the north of the origin. If  $R$  is the rectangle that represents Colorado, then the average snowfall for the state on December 20–21 was

$$f_{\text{ave}} = \frac{1}{A(R)} \iint_R f(x, y) \, dA$$

where  $A(R) = 388 \cdot 276$ . To estimate the value of this double integral, let's use the Midpoint Rule with  $m = n = 4$ . In other words, we divide  $R$  into 16 subrectangles of equal size, as in Figure 13. The area of each subrectangle is

$$\Delta A = \frac{1}{16}(388)(276) = 6693 \text{ mi}^2$$

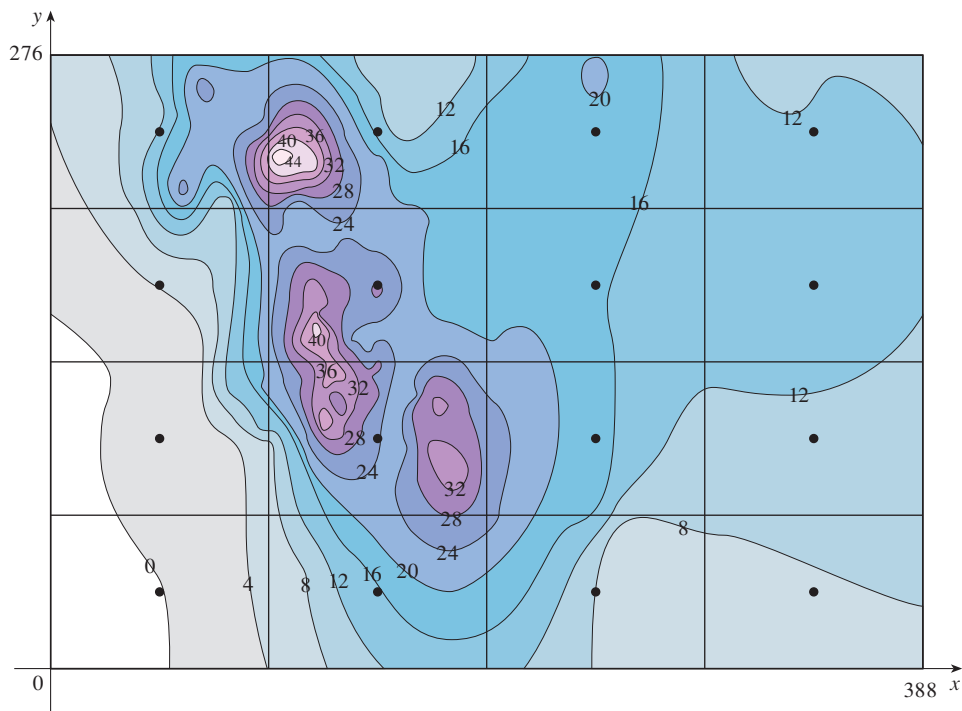


FIGURE 13

Using the contour map to estimate the value of  $f$  at the center of each subrectangle, we get

$$\begin{aligned} \iint_R f(x, y) \, dA &\approx \sum_{i=1}^4 \sum_{j=1}^4 f(\bar{x}_i, \bar{y}_j) \Delta A \\ &\approx \Delta A [0 + 15 + 8 + 7 + 2 + 25 + 18.5 + 11 \\ &\quad + 4.5 + 28 + 17 + 13.5 + 12 + 15 + 17.5 + 13] \\ &= (6693)(207) \end{aligned}$$

Therefore

$$f_{\text{ave}} \approx \frac{(6693)(207)}{(388)(276)} \approx 12.9$$

On December 20–21, 2006, Colorado received an average of approximately 13 inches of snow. ■



### Properties of Double Integrals

We list here three properties of double integrals that can be proved in the same manner as in Section 5.2. We assume that all of the integrals exist. Properties 7 and 8 are referred to as the *linearity* of the integral.

$$\boxed{7} \quad \iint_R [f(x, y) + g(x, y)] dA = \iint_R f(x, y) dA + \iint_R g(x, y) dA$$

Double integrals behave this way because the double sums that define them behave this way.

$$\boxed{8} \quad \iint_R cf(x, y) dA = c \iint_R f(x, y) dA \quad \text{where } c \text{ is a constant}$$

If  $f(x, y) \geq g(x, y)$  for all  $(x, y)$  in  $R$ , then

$$\boxed{9} \quad \iint_R f(x, y) dA \geq \iint_R g(x, y) dA$$

## 15.1 Exercises

1. (a) Estimate the volume of the solid that lies below the surface  $z = xy$  and above the rectangle

$$R = \{(x, y) \mid 0 \leq x \leq 6, 0 \leq y \leq 4\}$$

Use a Riemann sum with  $m = 3$ ,  $n = 2$ , and take the sample point to be the upper right corner of each square.

- (b) Use the Midpoint Rule to estimate the volume of the solid in part (a).
2. If  $R = [0, 4] \times [-1, 2]$ , use a Riemann sum with  $m = 2$ ,  $n = 3$  to estimate the value of  $\iint_R (1 - xy^2) dA$ . Take the sample points to be (a) the lower right corners and (b) the upper left corners of the rectangles.
3. (a) Use a Riemann sum with  $m = n = 2$  to estimate the value of  $\iint_R xe^{-xy} dA$ , where  $R = [0, 2] \times [0, 1]$ . Take the sample points to be upper right corners.  
(b) Use the Midpoint Rule to estimate the integral in part (a).
4. (a) Estimate the volume of the solid that lies below the surface  $z = 1 + x^2 + 3y$  and above the rectangle  $R = [1, 2] \times [0, 3]$ . Use a Riemann sum with  $m = n = 2$  and choose the sample points to be lower left corners.  
(b) Use the Midpoint Rule to estimate the volume in part (a).
5. A table of values is given for a function  $f(x, y)$  defined on  $R = [0, 4] \times [2, 4]$ .
- (a) Estimate  $\iint_R f(x, y) dA$  using the Midpoint Rule with  $m = n = 2$ .

- (b) Estimate the double integral with  $m = n = 4$  by choosing the sample points to be the points closest to the origin.

$x \backslash y$	2.0	2.5	3.0	3.5	4.0
0	-3	-5	-6	-4	-1
1	-1	-2	-3	-1	1
2	1	0	-1	1	4
3	2	2	1	3	7
4	3	4	2	5	9

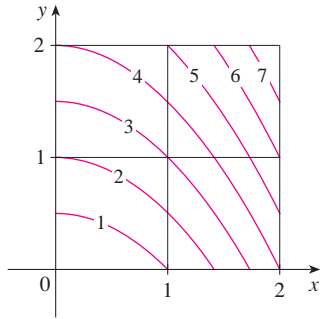
6. A 20-ft-by-30-ft swimming pool is filled with water. The depth is measured at 5-ft intervals, starting at one corner of the pool, and the values are recorded in the table. Estimate the volume of water in the pool.

	0	5	10	15	20	25	30
0	2	3	4	6	7	8	8
5	2	3	4	7	8	10	8
10	2	4	6	8	10	12	10
15	2	3	4	5	6	8	7
20	2	2	2	2	3	4	4

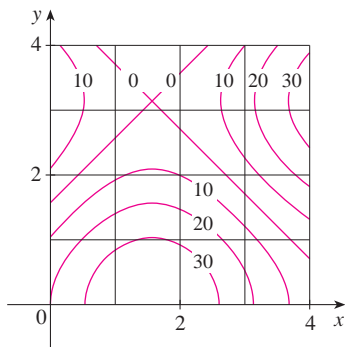
7. Let  $V$  be the volume of the solid that lies under the graph of  $f(x, y) = \sqrt{52 - x^2 - y^2}$  and above the rectangle given by  $2 \leq x \leq 4$ ,  $2 \leq y \leq 6$ . We use the lines  $x = 3$  and  $y = 4$  to

divide  $R$  into subrectangles. Let  $L$  and  $U$  be the Riemann sums computed using lower left corners and upper right corners, respectively. Without calculating the numbers  $V$ ,  $L$ , and  $U$ , arrange them in increasing order and explain your reasoning.

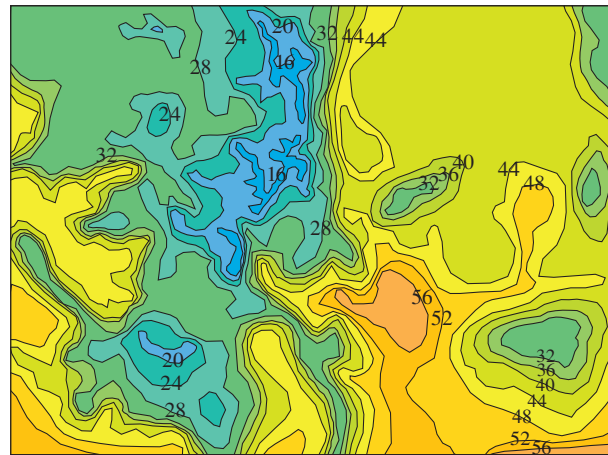
8. The figure shows level curves of a function  $f$  in the square  $R = [0, 2] \times [0, 2]$ . Use the Midpoint Rule with  $m = n = 2$  to estimate  $\iint_R f(x, y) \, dA$ . How could you improve your estimate?



9. A contour map is shown for a function  $f$  on the square  $R = [0, 4] \times [0, 4]$ .
- Use the Midpoint Rule with  $m = n = 2$  to estimate the value of  $\iint_R f(x, y) \, dA$ .
  - Estimate the average value of  $f$ .



10. The contour map shows the temperature, in degrees Fahrenheit, at 4:00 PM on February 26, 2007, in Colorado. (The state measures 388 mi west to east and 276 mi south to north.) Use the Midpoint Rule with  $m = n = 4$  to estimate the average temperature in Colorado at that time.



11–13 Evaluate the double integral by first identifying it as the volume of a solid.

- $\iint_R 3 \, dA$ ,  $R = \{(x, y) \mid -2 \leq x \leq 2, 1 \leq y \leq 6\}$
- $\iint_R (5 - x) \, dA$ ,  $R = \{(x, y) \mid 0 \leq x \leq 5, 0 \leq y \leq 3\}$
- $\iint_R (4 - 2y) \, dA$ ,  $R = [0, 1] \times [0, 1]$

- The integral  $\iint_R \sqrt{9 - y^2} \, dA$ , where  $R = [0, 4] \times [0, 2]$ , represents the volume of a solid. Sketch the solid.
- Use a programmable calculator or computer (or the sum command on a CAS) to estimate

$$\iint_R \sqrt{1 + xe^{-y}} \, dA$$

where  $R = [0, 1] \times [0, 1]$ . Use the Midpoint Rule with the following numbers of squares of equal size: 1, 4, 16, 64, 256, and 1024.

- Repeat Exercise 15 for the integral  $\iint_R \sin(x + \sqrt{y}) \, dA$ .
- If  $f$  is a constant function,  $f(x, y) = k$ , and  $R = [a, b] \times [c, d]$ , show that

$$\iint_R k \, dA = k(b - a)(d - c)$$

18. Use the result of Exercise 17 to show that

$$0 \leq \iint_R \sin \pi x \cos \pi y \, dA \leq \frac{1}{32}$$

where  $R = [0, \frac{1}{4}] \times [\frac{1}{4}, \frac{1}{2}]$ .

## 15.2 Iterated Integrals

Recall that it is usually difficult to evaluate single integrals directly from the definition of an integral, but the Fundamental Theorem of Calculus provides a much easier method. The evaluation of double integrals from first principles is even more difficult, but in this sec-

tion we see how to express a double integral as an iterated integral, which can then be evaluated by calculating two single integrals.

Suppose that  $f$  is a function of two variables that is integrable on the rectangle  $R = [a, b] \times [c, d]$ . We use the notation  $\int_c^d f(x, y) dy$  to mean that  $x$  is held fixed and  $f(x, y)$  is integrated with respect to  $y$  from  $y = c$  to  $y = d$ . This procedure is called *partial integration with respect to  $y$* . (Notice its similarity to partial differentiation.) Now  $\int_c^d f(x, y) dy$  is a number that depends on the value of  $x$ , so it defines a function of  $x$ :

$$A(x) = \int_c^d f(x, y) dy$$

If we now integrate the function  $A$  with respect to  $x$  from  $x = a$  to  $x = b$ , we get

$$\boxed{1} \quad \int_a^b A(x) dx = \int_a^b \left[ \int_c^d f(x, y) dy \right] dx$$

The integral on the right side of Equation 1 is called an **iterated integral**. Usually the brackets are omitted. Thus

$$\boxed{2} \quad \int_a^b \int_c^d f(x, y) dy dx = \int_a^b \left[ \int_c^d f(x, y) dy \right] dx$$

means that we first integrate with respect to  $y$  from  $c$  to  $d$  and then with respect to  $x$  from  $a$  to  $b$ .

Similarly, the iterated integral

$$\boxed{3} \quad \int_c^d \int_a^b f(x, y) dx dy = \int_c^d \left[ \int_a^b f(x, y) dx \right] dy$$

means that we first integrate with respect to  $x$  (holding  $y$  fixed) from  $x = a$  to  $x = b$  and then we integrate the resulting function of  $y$  with respect to  $y$  from  $y = c$  to  $y = d$ . Notice that in both Equations 2 and 3 we work *from the inside out*.

**EXAMPLE 1** Evaluate the iterated integrals.

$$(a) \int_0^3 \int_1^2 x^2 y dy dx \qquad (b) \int_1^2 \int_0^3 x^2 y dx dy$$

**SOLUTION**

(a) Regarding  $x$  as a constant, we obtain

$$\int_1^2 x^2 y dy = \left[ x^2 \frac{y^2}{2} \right]_{y=1}^{y=2} = x^2 \left( \frac{2^2}{2} \right) - x^2 \left( \frac{1^2}{2} \right) = \frac{3}{2} x^2$$

Thus the function  $A$  in the preceding discussion is given by  $A(x) = \frac{3}{2}x^2$  in this example. We now integrate this function of  $x$  from 0 to 3:

$$\begin{aligned} \int_0^3 \int_1^2 x^2 y dy dx &= \int_0^3 \left[ \int_1^2 x^2 y dy \right] dx \\ &= \int_0^3 \frac{3}{2} x^2 dx = \frac{x^3}{2} \Big|_0^3 = \frac{27}{2} \end{aligned}$$

(b) Here we first integrate with respect to  $x$ :

$$\begin{aligned} \int_1^2 \int_0^3 x^2 y \, dx \, dy &= \int_1^2 \left[ \int_0^3 x^2 y \, dx \right] dy = \int_1^2 \left[ \frac{x^3}{3} y \right]_{x=0}^{x=3} dy \\ &= \int_1^2 9y \, dy = 9 \left[ \frac{y^2}{2} \right]_1^2 = \frac{27}{2} \end{aligned}$$

Notice that in Example 1 we obtained the same answer whether we integrated with respect to  $y$  or  $x$  first. In general, it turns out (see Theorem 4) that the two iterated integrals in Equations 2 and 3 are always equal; that is, the order of integration does not matter. (This is similar to Clairaut's Theorem on the equality of the mixed partial derivatives.)

The following theorem gives a practical method for evaluating a double integral by expressing it as an iterated integral (in either order).

Theorem 4 is named after the Italian mathematician Guido Fubini (1879–1943), who proved a very general version of this theorem in 1907. But the version for continuous functions was known to the French mathematician Augustin-Louis Cauchy almost a century earlier.

**4 Fubini's Theorem** If  $f$  is continuous on the rectangle  $R = \{(x, y) \mid a \leq x \leq b, c \leq y \leq d\}$ , then

$$\iint_R f(x, y) \, dA = \int_a^b \int_c^d f(x, y) \, dy \, dx = \int_c^d \int_a^b f(x, y) \, dx \, dy$$

More generally, this is true if we assume that  $f$  is bounded on  $R$ ,  $f$  is discontinuous only on a finite number of smooth curves, and the iterated integrals exist.

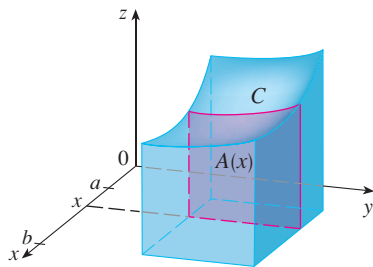


FIGURE 1

**TEC** Visual 15.2 illustrates Fubini's Theorem by showing an animation of Figures 1 and 2.

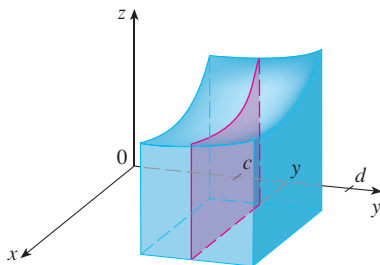


FIGURE 2

The proof of Fubini's Theorem is too difficult to include in this book, but we can at least give an intuitive indication of why it is true for the case where  $f(x, y) \geq 0$ . Recall that if  $f$  is positive, then we can interpret the double integral  $\iint_R f(x, y) \, dA$  as the volume  $V$  of the solid  $S$  that lies above  $R$  and under the surface  $z = f(x, y)$ . But we have another formula that we used for volume in Chapter 6, namely,

$$V = \int_a^b A(x) \, dx$$

where  $A(x)$  is the area of a cross-section of  $S$  in the plane through  $x$  perpendicular to the  $x$ -axis. From Figure 1 you can see that  $A(x)$  is the area under the curve  $C$  whose equation is  $z = f(x, y)$ , where  $x$  is held constant and  $c \leq y \leq d$ . Therefore

$$A(x) = \int_c^d f(x, y) \, dy$$

and we have

$$\iint_R f(x, y) \, dA = V = \int_a^b A(x) \, dx = \int_a^b \int_c^d f(x, y) \, dy \, dx$$

A similar argument, using cross-sections perpendicular to the  $y$ -axis as in Figure 2, shows that

$$\iint_R f(x, y) \, dA = \int_c^d \int_a^b f(x, y) \, dx \, dy$$

**V EXAMPLE 2** Evaluate the double integral  $\iint_R (x - 3y^2) dA$ , where  $R = \{(x, y) \mid 0 \leq x \leq 2, 1 \leq y \leq 2\}$ . (Compare with Example 3 in Section 15.1.)

**SOLUTION 1** Fubini's Theorem gives

$$\begin{aligned}\iint_R (x - 3y^2) dA &= \int_0^2 \int_1^2 (x - 3y^2) dy dx = \int_0^2 [xy - y^3]_{y=1}^{y=2} dx \\ &= \int_0^2 (x - 7) dx = \left. \frac{x^2}{2} - 7x \right|_0^2 = -12\end{aligned}$$

**SOLUTION 2** Again applying Fubini's Theorem, but this time integrating with respect to  $x$  first, we have

$$\begin{aligned}\iint_R (x - 3y^2) dA &= \int_1^2 \int_0^2 (x - 3y^2) dx dy \\ &= \int_1^2 \left[ \frac{x^2}{2} - 3xy^2 \right]_{x=0}^{x=2} dy \\ &= \int_1^2 (2 - 6y^2) dy = [2y - 2y^3]_1^2 = -12\end{aligned}$$

Notice the negative answer in Example 2; nothing is wrong with that. The function  $f$  is not a positive function, so its integral doesn't represent a volume. From Figure 3 we see that  $f$  is always negative on  $R$ , so the value of the integral is the *negative* of the volume that lies *above* the graph of  $f$  and *below*  $R$ .

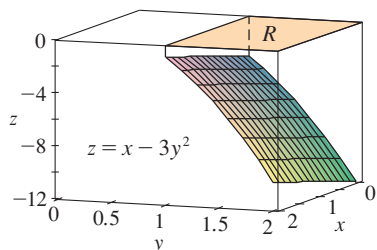


FIGURE 3

**V EXAMPLE 3** Evaluate  $\iint_R y \sin(xy) dA$ , where  $R = [1, 2] \times [0, \pi]$ .

**SOLUTION 1** If we first integrate with respect to  $x$ , we get

$$\begin{aligned}\iint_R y \sin(xy) dA &= \int_0^\pi \int_1^2 y \sin(xy) dx dy = \int_0^\pi [-\cos(xy)]_{x=1}^{x=2} dy \\ &= \int_0^\pi (-\cos 2y + \cos y) dy \\ &= -\frac{1}{2} \sin 2y + \sin y \Big|_0^\pi = 0\end{aligned}$$

**SOLUTION 2** If we reverse the order of integration, we get

$$\iint_R y \sin(xy) dA = \int_1^2 \int_0^\pi y \sin(xy) dy dx$$

To evaluate the inner integral, we use integration by parts with

$$\begin{aligned}u &= y & dv &= \sin(xy) dy \\ du &= dy & v &= -\frac{\cos(xy)}{x}\end{aligned}$$

and so

$$\begin{aligned}\int_0^\pi y \sin(xy) dy &= -\frac{y \cos(xy)}{x} \Big|_{y=0}^{y=\pi} + \frac{1}{x} \int_0^\pi \cos(xy) dy \\ &= -\frac{\pi \cos \pi x}{x} + \frac{1}{x^2} [\sin(xy)]_{y=0}^{y=\pi} \\ &= -\frac{\pi \cos \pi x}{x} + \frac{\sin \pi x}{x^2}\end{aligned}$$

For a function  $f$  that takes on both positive and negative values,  $\iint_R f(x, y) dA$  is a difference of volumes:  $V_1 - V_2$ , where  $V_1$  is the volume above  $R$  and below the graph of  $f$ , and  $V_2$  is the volume below  $R$  and above the graph. The fact that the integral in Example 3 is 0 means that these two volumes  $V_1$  and  $V_2$  are equal. (See Figure 4.)

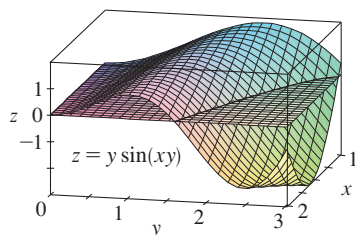


FIGURE 4

If we now integrate the first term by parts with  $u = -1/x$  and  $dv = \pi \cos \pi x \, dx$ , we get  $du = dx/x^2$ ,  $v = \sin \pi x$ , and

$$\int \left( -\frac{\pi \cos \pi x}{x} \right) dx = -\frac{\sin \pi x}{x} - \int \frac{\sin \pi x}{x^2} dx$$

Therefore 
$$\int \left( -\frac{\pi \cos \pi x}{x} + \frac{\sin \pi x}{x^2} \right) dx = -\frac{\sin \pi x}{x}$$

and so 
$$\int_1^2 \int_0^\pi y \sin(xy) \, dy \, dx = \left[ -\frac{\sin \pi x}{x} \right]_1^2 = -\frac{\sin 2\pi}{2} + \sin \pi = 0$$

In Example 2, Solutions 1 and 2 are equally straightforward, but in Example 3 the first solution is much easier than the second one. Therefore, when we evaluate double integrals, it's wise to choose the order of integration that gives simpler integrals.

**EXAMPLE 4** Find the volume of the solid  $S$  that is bounded by the elliptic paraboloid  $x^2 + 2y^2 + z = 16$ , the planes  $x = 2$  and  $y = 2$ , and the three coordinate planes.

**SOLUTION** We first observe that  $S$  is the solid that lies under the surface  $z = 16 - x^2 - 2y^2$  and above the square  $R = [0, 2] \times [0, 2]$ . (See Figure 5.) This solid was considered in Example 1 in Section 15.1, but we are now in a position to evaluate the double integral using Fubini's Theorem. Therefore

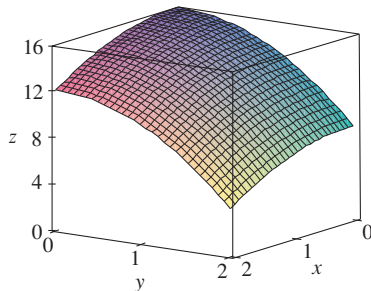


FIGURE 5

$$\begin{aligned} V &= \iint_R (16 - x^2 - 2y^2) \, dA = \int_0^2 \int_0^2 (16 - x^2 - 2y^2) \, dx \, dy \\ &= \int_0^2 \left[ 16x - \frac{1}{3}x^3 - 2y^2x \right]_{x=0}^{x=2} dy \\ &= \int_0^2 \left( \frac{88}{3} - 4y^2 \right) dy = \left[ \frac{88}{3}y - \frac{4}{3}y^3 \right]_0^2 = 48 \end{aligned}$$

In the special case where  $f(x, y)$  can be factored as the product of a function of  $x$  only and a function of  $y$  only, the double integral of  $f$  can be written in a particularly simple form. To be specific, suppose that  $f(x, y) = g(x)h(y)$  and  $R = [a, b] \times [c, d]$ . Then Fubini's Theorem gives

$$\iint_R f(x, y) \, dA = \int_c^d \int_a^b g(x)h(y) \, dx \, dy = \int_c^d \left[ \int_a^b g(x)h(y) \, dx \right] dy$$

In the inner integral,  $y$  is a constant, so  $h(y)$  is a constant and we can write

$$\int_c^d \left[ \int_a^b g(x)h(y) \, dx \right] dy = \int_c^d \left[ h(y) \left( \int_a^b g(x) \, dx \right) \right] dy = \int_a^b g(x) \, dx \int_c^d h(y) \, dy$$

since  $\int_a^b g(x) \, dx$  is a constant. Therefore, in this case, the double integral of  $f$  can be written as the product of two single integrals:

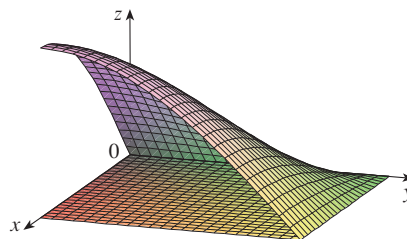
$$\boxed{5} \quad \iint_R g(x)h(y) \, dA = \int_a^b g(x) \, dx \int_c^d h(y) \, dy \quad \text{where } R = [a, b] \times [c, d]$$

**EXAMPLE 5** If  $R = [0, \pi/2] \times [0, \pi/2]$ , then, by Equation 5,

$$\begin{aligned} \iint_R \sin x \cos y \, dA &= \int_0^{\pi/2} \sin x \, dx \int_0^{\pi/2} \cos y \, dy \\ &= [-\cos x]_0^{\pi/2} [\sin y]_0^{\pi/2} = 1 \cdot 1 = 1 \end{aligned}$$

The function  $f(x, y) = \sin x \cos y$  in Example 5 is positive on  $R$ , so the integral represents the volume of the solid that lies above  $R$  and below the graph of  $f$  shown in Figure 6.

FIGURE 6



## 15.2 Exercises

**1–2** Find  $\int_0^5 f(x, y) \, dx$  and  $\int_0^1 f(x, y) \, dy$ .

1.  $f(x, y) = 12x^2y^3$       2.  $f(x, y) = y + xe^y$

**3–14** Calculate the iterated integral.

3.  $\int_1^4 \int_0^2 (6x^2y - 2x) \, dy \, dx$       4.  $\int_0^1 \int_1^2 (4x^3 - 9x^2y^2) \, dy \, dx$
5.  $\int_0^2 \int_0^4 y^3 e^{2x} \, dy \, dx$       6.  $\int_{\pi/6}^{\pi/2} \int_{-1}^5 \cos y \, dx \, dy$
7.  $\int_{-3}^3 \int_0^{\pi/2} (y + y^2 \cos x) \, dx \, dy$       8.  $\int_1^3 \int_1^5 \frac{\ln y}{xy} \, dy \, dx$
9.  $\int_1^4 \int_1^2 \left( \frac{x}{y} + \frac{y}{x} \right) \, dy \, dx$       10.  $\int_0^1 \int_0^3 e^{x+3y} \, dx \, dy$
11.  $\int_0^1 \int_0^1 v(u + v^2)^4 \, du \, dv$       12.  $\int_0^1 \int_0^1 xy\sqrt{x^2 + y^2} \, dy \, dx$
13.  $\int_0^2 \int_0^\pi r \sin^2 \theta \, d\theta \, dr$       14.  $\int_0^1 \int_0^1 \sqrt{s+t} \, ds \, dt$

**15–22** Calculate the double integral.

15.  $\iint_R \sin(x - y) \, dA$ ,  $R = \{(x, y) \mid 0 \leq x \leq \pi/2, 0 \leq y \leq \pi/2\}$
16.  $\iint_R (y + xy^{-2}) \, dA$ ,  $R = \{(x, y) \mid 0 \leq x \leq 2, 1 \leq y \leq 2\}$
17.  $\iint_R \frac{xy^2}{x^2 + 1} \, dA$ ,  $R = \{(x, y) \mid 0 \leq x \leq 1, -3 \leq y \leq 3\}$

18.  $\iint_R \frac{1 + x^2}{1 + y^2} \, dA$ ,  $R = \{(x, y) \mid 0 \leq x \leq 1, 0 \leq y \leq 1\}$

19.  $\iint_R x \sin(x + y) \, dA$ ,  $R = [0, \pi/6] \times [0, \pi/3]$

20.  $\iint_R \frac{x}{1 + xy} \, dA$ ,  $R = [0, 1] \times [0, 1]$

21.  $\iint_R ye^{-xy} \, dA$ ,  $R = [0, 2] \times [0, 3]$

22.  $\iint_R \frac{1}{1 + x + y} \, dA$ ,  $R = [1, 3] \times [1, 2]$

**23–24** Sketch the solid whose volume is given by the iterated integral.

23.  $\int_0^1 \int_0^1 (4 - x - 2y) \, dx \, dy$

24.  $\int_0^1 \int_0^1 (2 - x^2 - y^2) \, dy \, dx$

25. Find the volume of the solid that lies under the plane  $4x + 6y - 2z + 15 = 0$  and above the rectangle  $R = \{(x, y) \mid -1 \leq x \leq 2, -1 \leq y \leq 1\}$ .

26. Find the volume of the solid that lies under the hyperbolic paraboloid  $z = 3y^2 - x^2 + 2$  and above the rectangle  $R = [-1, 1] \times [1, 2]$ .




Graphing calculator or computer required





Computer algebra system required

1. Homework Hints available at [stewartcalculus.com](http://stewartcalculus.com)

27. Find the volume of the solid lying under the elliptic paraboloid  $x^2/4 + y^2/9 + z = 1$  and above the rectangle  $R = [-1, 1] \times [-2, 2]$ .
28. Find the volume of the solid enclosed by the surface  $z = 1 + e^x \sin y$  and the planes  $x = \pm 1$ ,  $y = 0$ ,  $y = \pi$ , and  $z = 0$ .
29. Find the volume of the solid enclosed by the surface  $z = x \sec^2 y$  and the planes  $z = 0$ ,  $x = 0$ ,  $x = 2$ ,  $y = 0$ , and  $y = \pi/4$ .
30. Find the volume of the solid in the first octant bounded by the cylinder  $z = 16 - x^2$  and the plane  $y = 5$ .
31. Find the volume of the solid enclosed by the paraboloid  $z = 2 + x^2 + (y - 2)^2$  and the planes  $z = 1$ ,  $x = 1$ ,  $x = -1$ ,  $y = 0$ , and  $y = 4$ .

 32. Graph the solid that lies between the surface  $z = 2xy/(x^2 + 1)$  and the plane  $z = x + 2y$  and is bounded by the planes  $x = 0$ ,  $x = 2$ ,  $y = 0$ , and  $y = 4$ . Then find its volume.

 33. Use a computer algebra system to find the exact value of the integral  $\iint_R x^5 y^3 e^{xy} dA$ , where  $R = [0, 1] \times [0, 1]$ . Then use the CAS to draw the solid whose volume is given by the integral.

 34. Graph the solid that lies between the surfaces  $z = e^{-x^2} \cos(x^2 + y^2)$  and  $z = 2 - x^2 - y^2$  for  $|x| \leq 1$ ,  $|y| \leq 1$ . Use a computer algebra system to approximate the volume of this solid correct to four decimal places.

35–36 Find the average value of  $f$  over the given rectangle.

35.  $f(x, y) = x^2 y$ ,  $R$  has vertices  $(-1, 0)$ ,  $(-1, 5)$ ,  $(1, 5)$ ,  $(1, 0)$

36.  $f(x, y) = e^y \sqrt{x + e^y}$ ,  $R = [0, 4] \times [0, 1]$

37–38 Use symmetry to evaluate the double integral.

37.  $\iint_R \frac{xy}{1 + x^4} dA$ ,  $R = \{(x, y) \mid -1 \leq x \leq 1, 0 \leq y \leq 1\}$

38.  $\iint_R (1 + x^2 \sin y + y^2 \sin x) dA$ ,  $R = [-\pi, \pi] \times [-\pi, \pi]$

 39. Use your CAS to compute the iterated integrals

$$\int_0^1 \int_0^1 \frac{x-y}{(x+y)^3} dy dx \quad \text{and} \quad \int_0^1 \int_0^1 \frac{x-y}{(x+y)^3} dx dy$$

Do the answers contradict Fubini's Theorem? Explain what is happening.

40. (a) In what way are the theorems of Fubini and Clairaut similar?  
 (b) If  $f(x, y)$  is continuous on  $[a, b] \times [c, d]$  and

$$g(x, y) = \int_a^x \int_c^y f(s, t) dt ds$$

for  $a < x < b$ ,  $c < y < d$ , show that  $g_{xy} = g_{yx} = f(x, y)$ .

## 15.3 Double Integrals over General Regions

For single integrals, the region over which we integrate is always an interval. But for double integrals, we want to be able to integrate a function  $f$  not just over rectangles but also over regions  $D$  of more general shape, such as the one illustrated in Figure 1. We suppose that  $D$  is a bounded region, which means that  $D$  can be enclosed in a rectangular region  $R$  as in Figure 2. Then we define a new function  $F$  with domain  $R$  by

$$\mathbf{1} \quad F(x, y) = \begin{cases} f(x, y) & \text{if } (x, y) \text{ is in } D \\ 0 & \text{if } (x, y) \text{ is in } R \text{ but not in } D \end{cases}$$

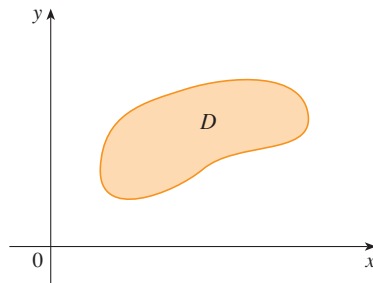


FIGURE 1

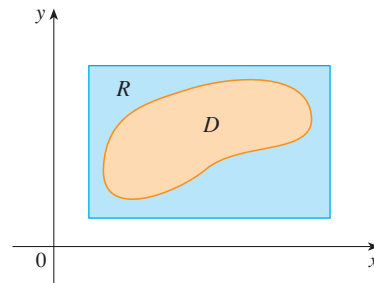


FIGURE 2



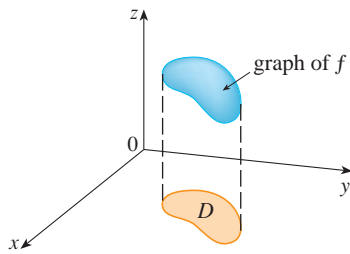


FIGURE 3

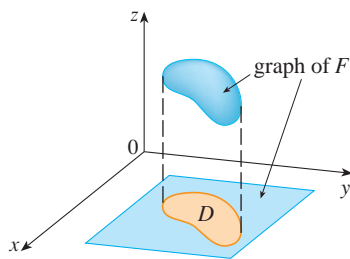


FIGURE 4

If  $F$  is integrable over  $R$ , then we define the **double integral of  $f$  over  $D$**  by

$$\boxed{2} \quad \iint_D f(x, y) \, dA = \iint_R F(x, y) \, dA \quad \text{where } F \text{ is given by Equation 1}$$

Definition 2 makes sense because  $R$  is a rectangle and so  $\iint_R F(x, y) \, dA$  has been previously defined in Section 15.1. The procedure that we have used is reasonable because the values of  $F(x, y)$  are 0 when  $(x, y)$  lies outside  $D$  and so they contribute nothing to the integral. This means that it doesn't matter what rectangle  $R$  we use as long as it contains  $D$ .

In the case where  $f(x, y) \geq 0$ , we can still interpret  $\iint_D f(x, y) \, dA$  as the volume of the solid that lies above  $D$  and under the surface  $z = f(x, y)$  (the graph of  $f$ ). You can see that this is reasonable by comparing the graphs of  $f$  and  $F$  in Figures 3 and 4 and remembering that  $\iint_R F(x, y) \, dA$  is the volume under the graph of  $F$ .

Figure 4 also shows that  $F$  is likely to have discontinuities at the boundary points of  $D$ . Nonetheless, if  $f$  is continuous on  $D$  and the boundary curve of  $D$  is “well behaved” (in a sense outside the scope of this book), then it can be shown that  $\iint_R F(x, y) \, dA$  exists and therefore  $\iint_D f(x, y) \, dA$  exists. In particular, this is the case for the following two types of regions.

A plane region  $D$  is said to be of **type I** if it lies between the graphs of two continuous functions of  $x$ , that is,

$$D = \{(x, y) \mid a \leq x \leq b, g_1(x) \leq y \leq g_2(x)\}$$

where  $g_1$  and  $g_2$  are continuous on  $[a, b]$ . Some examples of type I regions are shown in Figure 5.

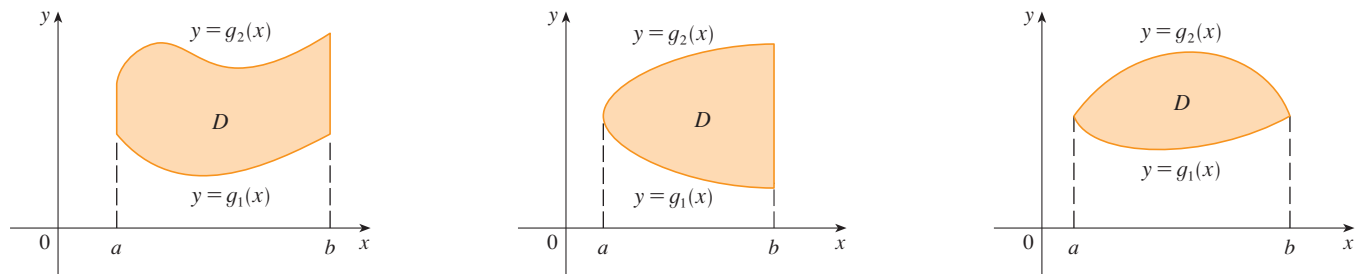


FIGURE 5 Some type I regions

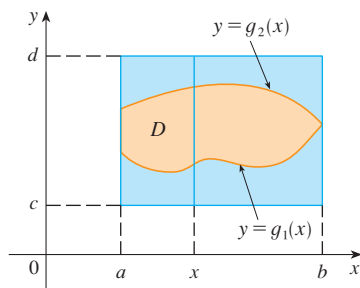


FIGURE 6

In order to evaluate  $\iint_D f(x, y) \, dA$  when  $D$  is a region of type I, we choose a rectangle  $R = [a, b] \times [c, d]$  that contains  $D$ , as in Figure 6, and we let  $F$  be the function given by Equation 1; that is,  $F$  agrees with  $f$  on  $D$  and  $F$  is 0 outside  $D$ . Then, by Fubini's Theorem,

$$\iint_D f(x, y) \, dA = \iint_R F(x, y) \, dA = \int_a^b \int_c^d F(x, y) \, dy \, dx$$

Observe that  $F(x, y) = 0$  if  $y < g_1(x)$  or  $y > g_2(x)$  because  $(x, y)$  then lies outside  $D$ . Therefore

$$\int_c^d F(x, y) \, dy = \int_{g_1(x)}^{g_2(x)} F(x, y) \, dy = \int_{g_1(x)}^{g_2(x)} f(x, y) \, dy$$

because  $F(x, y) = f(x, y)$  when  $g_1(x) \leq y \leq g_2(x)$ . Thus we have the following formula that enables us to evaluate the double integral as an iterated integral.

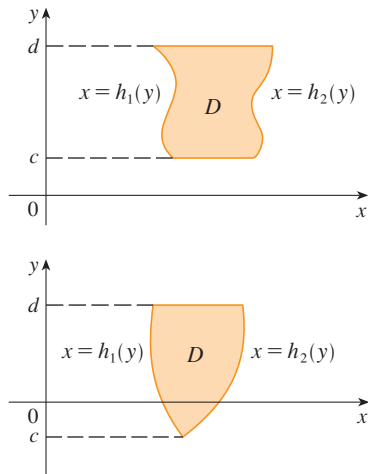


FIGURE 7  
Some type II regions

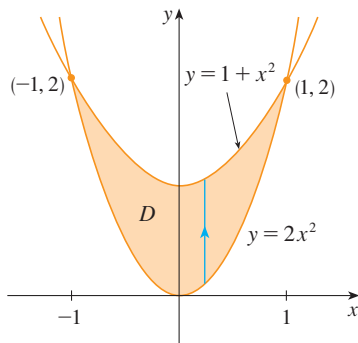


FIGURE 8

**3** If  $f$  is continuous on a type I region  $D$  such that

$$D = \{(x, y) \mid a \leq x \leq b, g_1(x) \leq y \leq g_2(x)\}$$

then

$$\iint_D f(x, y) \, dA = \int_a^b \int_{g_1(x)}^{g_2(x)} f(x, y) \, dy \, dx$$

The integral on the right side of **3** is an iterated integral that is similar to the ones we considered in the preceding section, except that in the inner integral we regard  $x$  as being constant not only in  $f(x, y)$  but also in the limits of integration,  $g_1(x)$  and  $g_2(x)$ .

We also consider plane regions of **type II**, which can be expressed as

$$**4** \quad D = \{(x, y) \mid c \leq y \leq d, h_1(y) \leq x \leq h_2(y)\}$$

where  $h_1$  and  $h_2$  are continuous. Two such regions are illustrated in Figure 7.

Using the same methods that were used in establishing **3**, we can show that

$$**5** \quad \iint_D f(x, y) \, dA = \int_c^d \int_{h_1(y)}^{h_2(y)} f(x, y) \, dx \, dy$$

where  $D$  is a type II region given by Equation 4.

**V EXAMPLE 1** Evaluate  $\iint_D (x + 2y) \, dA$ , where  $D$  is the region bounded by the parabolas  $y = 2x^2$  and  $y = 1 + x^2$ .

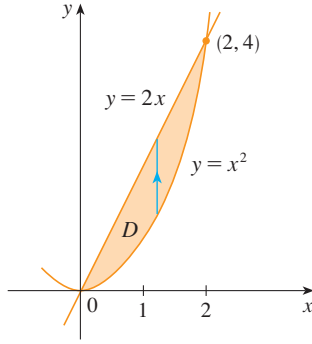
**SOLUTION** The parabolas intersect when  $2x^2 = 1 + x^2$ , that is,  $x^2 = 1$ , so  $x = \pm 1$ . We note that the region  $D$ , sketched in Figure 8, is a type I region but not a type II region and we can write

$$D = \{(x, y) \mid -1 \leq x \leq 1, 2x^2 \leq y \leq 1 + x^2\}$$

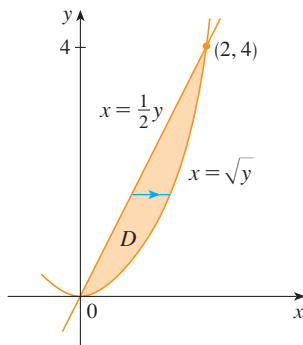
Since the lower boundary is  $y = 2x^2$  and the upper boundary is  $y = 1 + x^2$ , Equation 3 gives

$$\begin{aligned} \iint_D (x + 2y) \, dA &= \int_{-1}^1 \int_{2x^2}^{1+x^2} (x + 2y) \, dy \, dx \\ &= \int_{-1}^1 [xy + y^2]_{y=2x^2}^{y=1+x^2} \, dx \\ &= \int_{-1}^1 [x(1 + x^2) + (1 + x^2)^2 - x(2x^2) - (2x^2)^2] \, dx \\ &= \int_{-1}^1 (-3x^4 - x^3 + 2x^2 + x + 1) \, dx \\ &= -3 \frac{x^5}{5} - \frac{x^4}{4} + 2 \frac{x^3}{3} + \frac{x^2}{2} + x \Big|_{-1}^1 = \frac{32}{15} \end{aligned}$$

**NOTE** When we set up a double integral as in Example 1, it is essential to draw a diagram. Often it is helpful to draw a vertical arrow as in Figure 8. Then the limits of integration for the *inner* integral can be read from the diagram as follows: The arrow starts at the lower boundary  $y = g_1(x)$ , which gives the lower limit in the integral, and the arrow ends at the upper boundary  $y = g_2(x)$ , which gives the upper limit of integration. For a type II region the arrow is drawn horizontally from the left boundary to the right boundary.

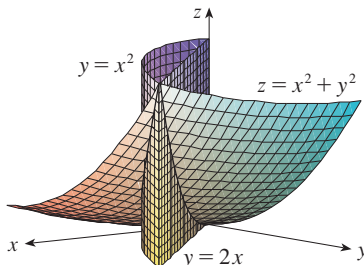


**FIGURE 9**  
 $D$  as a type I region



**FIGURE 10**  
 $D$  as a type II region

Figure 11 shows the solid whose volume is calculated in Example 2. It lies above the  $xy$ -plane, below the paraboloid  $z = x^2 + y^2$ , and between the plane  $y = 2x$  and the parabolic cylinder  $y = x^2$ .



**FIGURE 11**

**EXAMPLE 2** Find the volume of the solid that lies under the paraboloid  $z = x^2 + y^2$  and above the region  $D$  in the  $xy$ -plane bounded by the line  $y = 2x$  and the parabola  $y = x^2$ .

**SOLUTION 1** From Figure 9 we see that  $D$  is a type I region and

$$D = \{(x, y) \mid 0 \leq x \leq 2, x^2 \leq y \leq 2x\}$$

Therefore the volume under  $z = x^2 + y^2$  and above  $D$  is

$$\begin{aligned} V &= \iint_D (x^2 + y^2) dA = \int_0^2 \int_{x^2}^{2x} (x^2 + y^2) dy dx \\ &= \int_0^2 \left[ x^2 y + \frac{y^3}{3} \right]_{y=x^2}^{y=2x} dx \\ &= \int_0^2 \left[ x^2(2x) + \frac{(2x)^3}{3} - x^2 x^2 - \frac{(x^2)^3}{3} \right] dx \\ &= \int_0^2 \left( -\frac{x^6}{3} - x^4 + \frac{14x^3}{3} \right) dx \\ &= \left[ -\frac{x^7}{21} - \frac{x^5}{5} + \frac{7x^4}{6} \right]_0^2 = \frac{216}{35} \end{aligned}$$

**SOLUTION 2** From Figure 10 we see that  $D$  can also be written as a type II region:

$$D = \{(x, y) \mid 0 \leq y \leq 4, \frac{1}{2}y \leq x \leq \sqrt{y}\}$$

Therefore another expression for  $V$  is

$$\begin{aligned} V &= \iint_D (x^2 + y^2) dA = \int_0^4 \int_{\frac{1}{2}y}^{\sqrt{y}} (x^2 + y^2) dx dy \\ &= \int_0^4 \left[ \frac{x^3}{3} + y^2 x \right]_{x=\frac{1}{2}y}^{x=\sqrt{y}} dy = \int_0^4 \left( \frac{y^{3/2}}{3} + y^{5/2} - \frac{y^3}{24} - \frac{y^3}{2} \right) dy \\ &= \left[ \frac{2}{15} y^{5/2} + \frac{2}{7} y^{7/2} - \frac{13}{96} y^4 \right]_0^4 = \frac{216}{35} \end{aligned}$$

**V EXAMPLE 3** Evaluate  $\iint_D xy \, dA$ , where  $D$  is the region bounded by the line  $y = x - 1$  and the parabola  $y^2 = 2x + 6$ .

**SOLUTION** The region  $D$  is shown in Figure 12. Again  $D$  is both type I and type II, but the description of  $D$  as a type I region is more complicated because the lower boundary consists of two parts. Therefore we prefer to express  $D$  as a type II region:

$$D = \left\{ (x, y) \mid -2 \leq y \leq 4, \frac{1}{2}y^2 - 3 \leq x \leq y + 1 \right\}$$

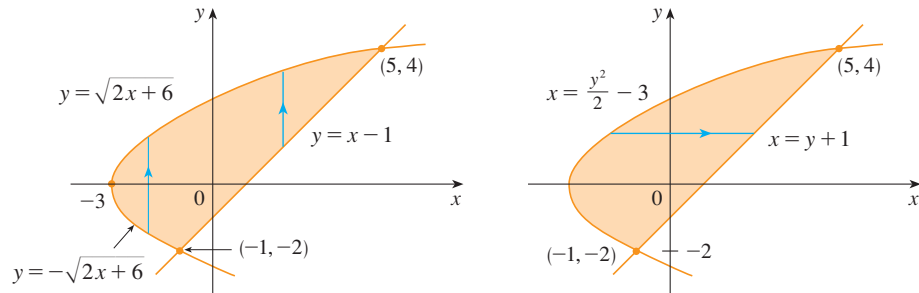


FIGURE 12

 (a)  $D$  as a type I region

 (b)  $D$  as a type II region

Then [5] gives

$$\begin{aligned} \iint_D xy \, dA &= \int_{-2}^4 \int_{\frac{1}{2}y^2-3}^{y+1} xy \, dx \, dy = \int_{-2}^4 \left[ \frac{x^2}{2} y \right]_{x=\frac{1}{2}y^2-3}^{x=y+1} dy \\ &= \frac{1}{2} \int_{-2}^4 y \left[ (y+1)^2 - \left( \frac{1}{2}y^2 - 3 \right)^2 \right] dy \\ &= \frac{1}{2} \int_{-2}^4 \left( -\frac{y^5}{4} + 4y^3 + 2y^2 - 8y \right) dy \\ &= \frac{1}{2} \left[ -\frac{y^6}{24} + y^4 + 2\frac{y^3}{3} - 4y^2 \right]_{-2}^4 = 36 \end{aligned}$$

If we had expressed  $D$  as a type I region using Figure 12(a), then we would have obtained

$$\iint_D xy \, dA = \int_{-3}^{-1} \int_{-\sqrt{2x+6}}^{\sqrt{2x+6}} xy \, dy \, dx + \int_{-1}^5 \int_{x-1}^{\sqrt{2x+6}} xy \, dy \, dx$$

but this would have involved more work than the other method.

**EXAMPLE 4** Find the volume of the tetrahedron bounded by the planes  $x + 2y + z = 2$ ,  $x = 2y$ ,  $x = 0$ , and  $z = 0$ .

**SOLUTION** In a question such as this, it's wise to draw two diagrams: one of the three-dimensional solid and another of the plane region  $D$  over which it lies. Figure 13 shows the tetrahedron  $T$  bounded by the coordinate planes  $x = 0$ ,  $z = 0$ , the vertical plane  $x = 2y$ , and the plane  $x + 2y + z = 2$ . Since the plane  $x + 2y + z = 2$  intersects the  $xy$ -plane (whose equation is  $z = 0$ ) in the line  $x + 2y = 2$ , we see that  $T$  lies above the triangular region  $D$  in the  $xy$ -plane bounded by the lines  $x = 2y$ ,  $x + 2y = 2$ , and  $x = 0$ . (See Figure 14.)

The plane  $x + 2y + z = 2$  can be written as  $z = 2 - x - 2y$ , so the required volume lies under the graph of the function  $z = 2 - x - 2y$  and above

$$D = \left\{ (x, y) \mid 0 \leq x \leq 1, x/2 \leq y \leq 1 - x/2 \right\}$$

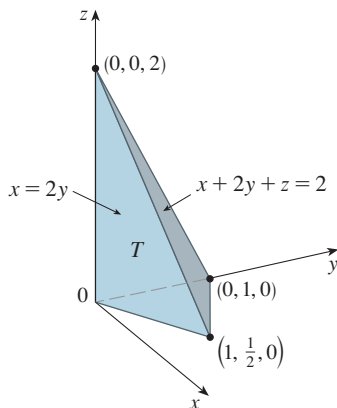


FIGURE 13

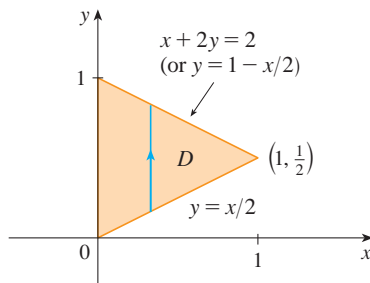
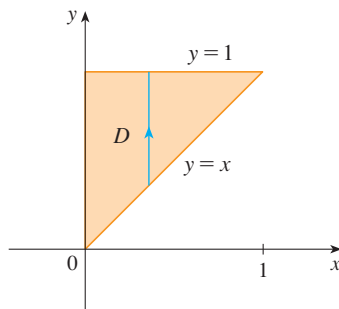


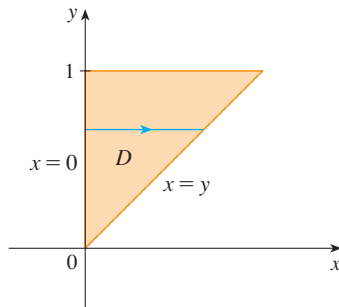
FIGURE 14

Therefore

$$\begin{aligned}
 V &= \iint_D (2 - x - 2y) \, dA \\
 &= \int_0^1 \int_{x/2}^{1-x/2} (2 - x - 2y) \, dy \, dx \\
 &= \int_0^1 [2y - xy - y^2]_{y=x/2}^{y=1-x/2} \, dx \\
 &= \int_0^1 \left[ 2 - x - x \left( 1 - \frac{x}{2} \right) - \left( 1 - \frac{x}{2} \right)^2 - x + \frac{x^2}{2} + \frac{x^2}{4} \right] \, dx \\
 &= \int_0^1 (x^2 - 2x + 1) \, dx = \left[ \frac{x^3}{3} - x^2 + x \right]_0^1 = \frac{1}{3}
 \end{aligned}$$



**FIGURE 15**  
 $D$  as a type I region



**FIGURE 16**  
 $D$  as a type II region

**V EXAMPLE 5** Evaluate the iterated integral  $\int_0^1 \int_x^1 \sin(y^2) \, dy \, dx$ .

**SOLUTION** If we try to evaluate the integral as it stands, we are faced with the task of first evaluating  $\int \sin(y^2) \, dy$ . But it's impossible to do so in finite terms since  $\int \sin(y^2) \, dy$  is not an elementary function. (See the end of Section 7.5.) So we must change the order of integration. This is accomplished by first expressing the given iterated integral as a double integral. Using [3] backward, we have

$$\int_0^1 \int_x^1 \sin(y^2) \, dy \, dx = \iint_D \sin(y^2) \, dA$$

where

$$D = \{(x, y) \mid 0 \leq x \leq 1, x \leq y \leq 1\}$$

We sketch this region  $D$  in Figure 15. Then from Figure 16 we see that an alternative description of  $D$  is

$$D = \{(x, y) \mid 0 \leq y \leq 1, 0 \leq x \leq y\}$$

This enables us to use [5] to express the double integral as an iterated integral in the reverse order:

$$\begin{aligned}
 \int_0^1 \int_x^1 \sin(y^2) \, dy \, dx &= \iint_D \sin(y^2) \, dA \\
 &= \int_0^1 \int_0^y \sin(y^2) \, dx \, dy = \int_0^1 [x \sin(y^2)]_{x=0}^{x=y} \, dy \\
 &= \int_0^1 y \sin(y^2) \, dy = \left[ -\frac{1}{2} \cos(y^2) \right]_0^1 = \frac{1}{2}(1 - \cos 1)
 \end{aligned}$$

### Properties of Double Integrals

We assume that all of the following integrals exist. The first three properties of double integrals over a region  $D$  follow immediately from Definition 2 in this section and Properties 7, 8, and 9 in Section 15.1.

$$\boxed{6} \quad \iint_D [f(x, y) + g(x, y)] \, dA = \iint_D f(x, y) \, dA + \iint_D g(x, y) \, dA$$

$$\boxed{7} \quad \iint_D cf(x, y) \, dA = c \iint_D f(x, y) \, dA$$

If  $f(x, y) \geq g(x, y)$  for all  $(x, y)$  in  $D$ , then

$$\boxed{8} \quad \iint_D f(x, y) \, dA \geq \iint_D g(x, y) \, dA$$

The next property of double integrals is similar to the property of single integrals given by the equation  $\int_a^b f(x) \, dx = \int_a^c f(x) \, dx + \int_c^b f(x) \, dx$ .

If  $D = D_1 \cup D_2$ , where  $D_1$  and  $D_2$  don't overlap except perhaps on their boundaries (see Figure 17), then

$$\boxed{9} \quad \iint_D f(x, y) \, dA = \iint_{D_1} f(x, y) \, dA + \iint_{D_2} f(x, y) \, dA$$

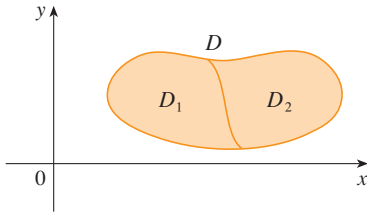


FIGURE 17

Property 9 can be used to evaluate double integrals over regions  $D$  that are neither type I nor type II but can be expressed as a union of regions of type I or type II. Figure 18 illustrates this procedure. (See Exercises 55 and 56.)

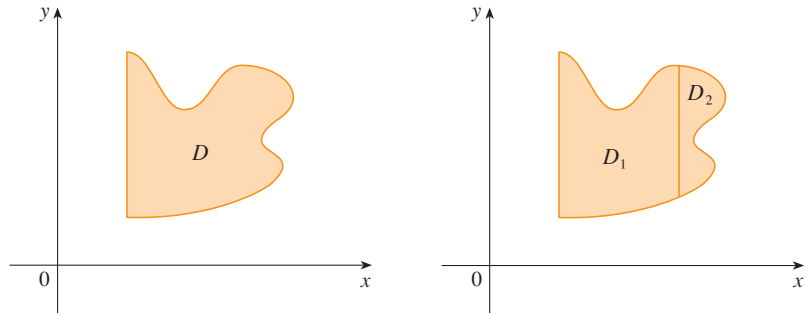


FIGURE 18

(a)  $D$  is neither type I nor type II.

(b)  $D = D_1 \cup D_2$ ,  $D_1$  is type I,  $D_2$  is type II.

The next property of integrals says that if we integrate the constant function  $f(x, y) = 1$  over a region  $D$ , we get the area of  $D$ :

$$\boxed{10} \quad \iint_D 1 \, dA = A(D)$$

Figure 19 illustrates why Equation 10 is true: A solid cylinder whose base is  $D$  and whose height is 1 has volume  $A(D) \cdot 1 = A(D)$ , but we know that we can also write its volume as  $\iint_D 1 \, dA$ .

Finally, we can combine Properties 7, 8, and 10 to prove the following property. (See Exercise 61.)

$\boxed{11}$  If  $m \leq f(x, y) \leq M$  for all  $(x, y)$  in  $D$ , then

$$mA(D) \leq \iint_D f(x, y) \, dA \leq MA(D)$$

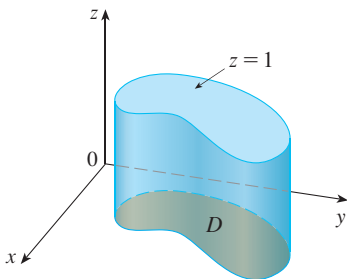


FIGURE 19

Cylinder with base  $D$  and height 1

**EXAMPLE 6** Use Property 11 to estimate the integral  $\iint_D e^{\sin x \cos y} dA$ , where  $D$  is the disk with center the origin and radius 2.

**SOLUTION** Since  $-1 \leq \sin x \leq 1$  and  $-1 \leq \cos y \leq 1$ , we have  $-1 \leq \sin x \cos y \leq 1$  and therefore

$$e^{-1} \leq e^{\sin x \cos y} \leq e^1 = e$$

Thus, using  $m = e^{-1} = 1/e$ ,  $M = e$ , and  $A(D) = \pi(2)^2$  in Property 11, we obtain

$$\frac{4\pi}{e} \leq \iint_D e^{\sin x \cos y} dA \leq 4\pi e$$

## 15.3 Exercises

**1–6** Evaluate the iterated integral.

- $\int_0^4 \int_0^{\sqrt{y}} xy^2 dx dy$
- $\int_0^1 \int_{2x}^2 (x - y) dy dx$
- $\int_0^1 \int_x^x (1 + 2y) dy dx$
- $\int_0^2 \int_y^{2y} xy dx dy$
- $\int_0^1 \int_0^{s^2} \cos(s^3) dt ds$
- $\int_0^1 \int_0^{e^v} \sqrt{1 + e^v} dw dv$

**7–10** Evaluate the double integral.

- $\iint_D y^2 dA$ ,  $D = \{(x, y) \mid -1 \leq y \leq 1, -y - 2 \leq x \leq y\}$
- $\iint_D \frac{y}{x^5 + 1} dA$ ,  $D = \{(x, y) \mid 0 \leq x \leq 1, 0 \leq y \leq x^2\}$
- $\iint_D x dA$ ,  $D = \{(x, y) \mid 0 \leq x \leq \pi, 0 \leq y \leq \sin x\}$
- $\iint_D x^3 dA$ ,  $D = \{(x, y) \mid 1 \leq x \leq e, 0 \leq y \leq \ln x\}$

**11.** Draw an example of a region that is

- type I but not type II
- type II but not type I

**12.** Draw an example of a region that is

- both type I and type II
- neither type I nor type II

**13–14** Express  $D$  as a region of type I and also as a region of type II. Then evaluate the double integral in two ways.

- $\iint_D x dA$ ,  $D$  is enclosed by the lines  $y = x$ ,  $y = 0$ ,  $x = 1$

- $\iint_D xy dA$ ,  $D$  is enclosed by the curves  $y = x^2$ ,  $y = 3x$

**15–16** Set up iterated integrals for both orders of integration. Then evaluate the double integral using the easier order and explain why it's easier.

- $\iint_D y dA$ ,  $D$  is bounded by  $y = x - 2$ ,  $x = y^2$

- $\iint_D y^2 e^{xy} dA$ ,  $D$  is bounded by  $y = x$ ,  $y = 4$ ,  $x = 0$

**17–22** Evaluate the double integral.

- $\iint_D x \cos y dA$ ,  $D$  is bounded by  $y = 0$ ,  $y = x^2$ ,  $x = 1$

- $\iint_D (x^2 + 2y) dA$ ,  $D$  is bounded by  $y = x$ ,  $y = x^3$ ,  $x \geq 0$

- $\iint_D y^2 dA$ ,  
 $D$  is the triangular region with vertices  $(0, 1)$ ,  $(1, 2)$ ,  $(4, 1)$



- $\iint_D xy^2 dA$ ,  $D$  is enclosed by  $x = 0$  and  $x = \sqrt{1 - y^2}$

- $\iint_D (2x - y) dA$ ,  
 $D$  is bounded by the circle with center the origin and radius 2

- $\iint_D 2xy dA$ ,  $D$  is the triangular region with vertices  $(0, 0)$ ,  $(1, 2)$ , and  $(0, 3)$

23–32 Find the volume of the given solid.

23. Under the plane  $x - 2y + z = 1$  and above the region bounded by  $x + y = 1$  and  $x^2 + y = 1$
24. Under the surface  $z = 1 + x^2y^2$  and above the region enclosed by  $x = y^2$  and  $x = 4$
25. Under the surface  $z = xy$  and above the triangle with vertices  $(1, 1)$ ,  $(4, 1)$ , and  $(1, 2)$
26. Enclosed by the paraboloid  $z = x^2 + 3y^2$  and the planes  $x = 0$ ,  $y = 1$ ,  $y = x$ ,  $z = 0$
27. Bounded by the coordinate planes and the plane  $3x + 2y + z = 6$
28. Bounded by the planes  $z = x$ ,  $y = x$ ,  $x + y = 2$ , and  $z = 0$
29. Enclosed by the cylinders  $z = x^2$ ,  $y = x^2$  and the planes  $z = 0$ ,  $y = 4$
30. Bounded by the cylinder  $y^2 + z^2 = 4$  and the planes  $x = 2y$ ,  $x = 0$ ,  $z = 0$  in the first octant
31. Bounded by the cylinder  $x^2 + y^2 = 1$  and the planes  $y = z$ ,  $x = 0$ ,  $z = 0$  in the first octant
32. Bounded by the cylinders  $x^2 + y^2 = r^2$  and  $y^2 + z^2 = r^2$


-  33. Use a graphing calculator or computer to estimate the  $x$ -coordinates of the points of intersection of the curves  $y = x^4$  and  $y = 3x - x^2$ . If  $D$  is the region bounded by these curves, estimate  $\iint_D x \, dA$ .
-  34. Find the approximate volume of the solid in the first octant that is bounded by the planes  $y = x$ ,  $z = 0$ , and  $z = x$  and the cylinder  $y = \cos x$ . (Use a graphing device to estimate the points of intersection.)

35–36 Find the volume of the solid by subtracting two volumes.

35. The solid enclosed by the parabolic cylinders  $y = 1 - x^2$ ,  $y = x^2 - 1$  and the planes  $x + y + z = 2$ ,  $2x + 2y - z + 10 = 0$
36. The solid enclosed by the parabolic cylinder  $y = x^2$  and the planes  $z = 3y$ ,  $z = 2 + y$

37–38 Sketch the solid whose volume is given by the iterated integral.

37.  $\int_0^1 \int_0^{1-x} (1 - x - y) \, dy \, dx$       38.  $\int_0^1 \int_0^{1-x^2} (1 - x) \, dy \, dx$

 39–42 Use a computer algebra system to find the exact volume of the solid.

39. Under the surface  $z = x^3y^4 + xy^2$  and above the region bounded by the curves  $y = x^3 - x$  and  $y = x^2 + x$  for  $x \geq 0$

40. Between the paraboloids  $z = 2x^2 + y^2$  and  $z = 8 - x^2 - 2y^2$  and inside the cylinder  $x^2 + y^2 = 1$
41. Enclosed by  $z = 1 - x^2 - y^2$  and  $z = 0$
42. Enclosed by  $z = x^2 + y^2$  and  $z = 2y$

43–48 Sketch the region of integration and change the order of integration.

43.  $\int_0^1 \int_0^y f(x, y) \, dx \, dy$       44.  $\int_0^2 \int_{x^2}^4 f(x, y) \, dy \, dx$

45.  $\int_0^{\pi/2} \int_0^{\cos x} f(x, y) \, dy \, dx$       46.  $\int_{-2}^2 \int_0^{\sqrt{4-y^2}} f(x, y) \, dx \, dy$

47.  $\int_1^2 \int_0^{\ln x} f(x, y) \, dy \, dx$       48.  $\int_0^1 \int_{\arctan x}^{\pi/4} f(x, y) \, dy \, dx$

49–54 Evaluate the integral by reversing the order of integration.

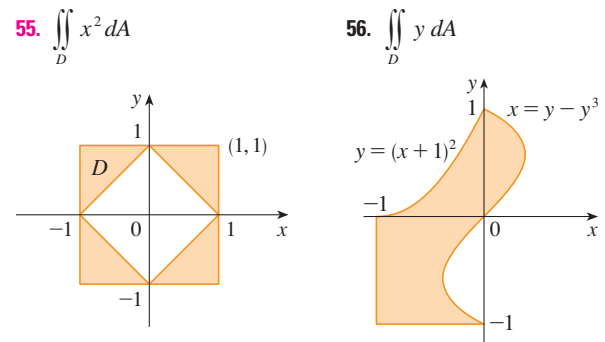
49.  $\int_0^1 \int_{3y}^3 e^{x^2} \, dx \, dy$       50.  $\int_0^{\sqrt{\pi}} \int_y^{\sqrt{\pi}} \cos(x^2) \, dx \, dy$

51.  $\int_0^4 \int_{\sqrt{x}}^2 \frac{1}{y^3 + 1} \, dy \, dx$       52.  $\int_0^1 \int_x^1 e^{x/y} \, dy \, dx$

53.  $\int_0^1 \int_{\arcsin y}^{\pi/2} \cos x \sqrt{1 + \cos^2 x} \, dx \, dy$

54.  $\int_0^8 \int_{\sqrt[3]{y}}^2 e^{x^4} \, dx \, dy$

55–56 Express  $D$  as a union of regions of type I or type II and evaluate the integral.



57–58 Use Property 11 to estimate the value of the integral.

57.  $\iint_Q e^{-(x^2+y^2)^2} \, dA$ ,  $Q$  is the quarter-circle with center the origin and radius  $\frac{1}{2}$  in the first quadrant
58.  $\iint_T \sin^4(x + y) \, dA$ ,  $T$  is the triangle enclosed by the lines  $y = 0$ ,  $y = 2x$ , and  $x = 1$



59–60 Find the average value of  $f$  over the region  $D$ .

59.  $f(x, y) = xy$ ,  $D$  is the triangle with vertices  $(0, 0)$ ,  $(1, 0)$ , and  $(1, 3)$

60.  $f(x, y) = x \sin y$ ,  $D$  is enclosed by the curves  $y = 0$ ,  $y = x^2$ , and  $x = 1$

61. Prove Property 11.

62. In evaluating a double integral over a region  $D$ , a sum of iterated integrals was obtained as follows:

$$\iint_D f(x, y) dA = \int_0^1 \int_0^{2y} f(x, y) dx dy + \int_1^3 \int_0^{3-y} f(x, y) dx dy$$

Sketch the region  $D$  and express the double integral as an iterated integral with reversed order of integration.

63–67 Use geometry or symmetry, or both, to evaluate the double integral.

63.  $\iint_D (x + 2) dA$ ,  $D = \{(x, y) \mid 0 \leq y \leq \sqrt{9 - x^2}\}$

64.  $\iint_D \sqrt{R^2 - x^2 - y^2} dA$ ,

$D$  is the disk with center the origin and radius  $R$

65.  $\iint_D (2x + 3y) dA$ ,

$D$  is the rectangle  $0 \leq x \leq a$ ,  $0 \leq y \leq b$

66.  $\iint_D (2 + x^2y^3 - y^2 \sin x) dA$ ,

$D = \{(x, y) \mid |x| + |y| \leq 1\}$

67.  $\iint_D (ax^3 + by^3 + \sqrt{a^2 - x^2}) dA$ ,

$D = [-a, a] \times [-b, b]$

**CAS** 68. Graph the solid bounded by the plane  $x + y + z = 1$  and the paraboloid  $z = 4 - x^2 - y^2$  and find its exact volume. (Use your CAS to do the graphing, to find the equations of the boundary curves of the region of integration, and to evaluate the double integral.)

## 15.4 Double Integrals in Polar Coordinates

Suppose that we want to evaluate a double integral  $\iint_R f(x, y) dA$ , where  $R$  is one of the regions shown in Figure 1. In either case the description of  $R$  in terms of rectangular coordinates is rather complicated, but  $R$  is easily described using polar coordinates.

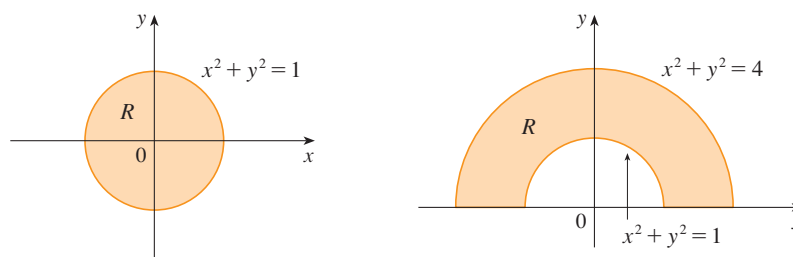


FIGURE 1

(a)  $R = \{(r, \theta) \mid 0 \leq r \leq 1, 0 \leq \theta \leq 2\pi\}$

(b)  $R = \{(r, \theta) \mid 1 \leq r \leq 2, 0 \leq \theta \leq \pi\}$

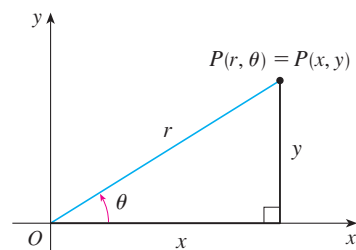


FIGURE 2

Recall from Figure 2 that the polar coordinates  $(r, \theta)$  of a point are related to the rectangular coordinates  $(x, y)$  by the equations

$$r^2 = x^2 + y^2 \quad x = r \cos \theta \quad y = r \sin \theta$$

(See Section 10.3.)

The regions in Figure 1 are special cases of a **polar rectangle**

$$R = \{(r, \theta) \mid a \leq r \leq b, \alpha \leq \theta \leq \beta\}$$

which is shown in Figure 3. In order to compute the double integral  $\iint_R f(x, y) \, dA$ , where  $R$  is a polar rectangle, we divide the interval  $[a, b]$  into  $m$  subintervals  $[r_{i-1}, r_i]$  of equal width  $\Delta r = (b - a)/m$  and we divide the interval  $[\alpha, \beta]$  into  $n$  subintervals  $[\theta_{j-1}, \theta_j]$  of equal width  $\Delta\theta = (\beta - \alpha)/n$ . Then the circles  $r = r_i$  and the rays  $\theta = \theta_j$  divide the polar rectangle  $R$  into the small polar rectangles  $R_{ij}$  shown in Figure 4.

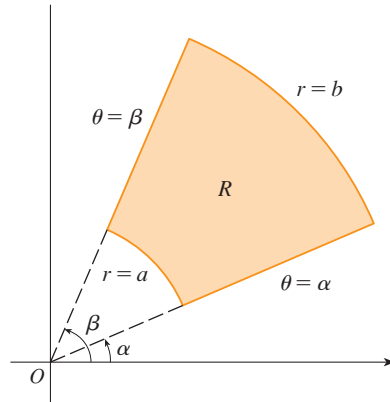


FIGURE 3 Polar rectangle

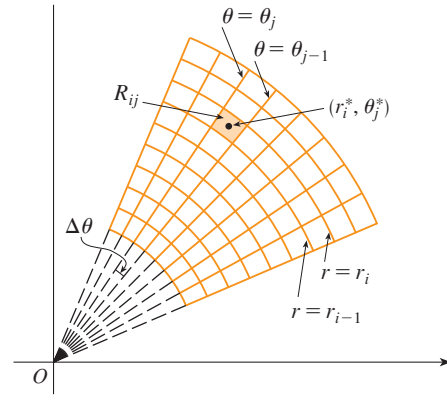


FIGURE 4 Dividing  $R$  into polar subrectangles

The “center” of the polar subrectangle

$$R_{ij} = \{(r, \theta) \mid r_{i-1} \leq r \leq r_i, \theta_{j-1} \leq \theta \leq \theta_j\}$$

has polar coordinates

$$r_i^* = \frac{1}{2}(r_{i-1} + r_i) \quad \theta_j^* = \frac{1}{2}(\theta_{j-1} + \theta_j)$$

We compute the area of  $R_{ij}$  using the fact that the area of a sector of a circle with radius  $r$  and central angle  $\theta$  is  $\frac{1}{2}r^2\theta$ . Subtracting the areas of two such sectors, each of which has central angle  $\Delta\theta = \theta_j - \theta_{j-1}$ , we find that the area of  $R_{ij}$  is

$$\begin{aligned} \Delta A_i &= \frac{1}{2}r_i^2 \Delta\theta - \frac{1}{2}r_{i-1}^2 \Delta\theta = \frac{1}{2}(r_i^2 - r_{i-1}^2) \Delta\theta \\ &= \frac{1}{2}(r_i + r_{i-1})(r_i - r_{i-1}) \Delta\theta = r_i^* \Delta r \Delta\theta \end{aligned}$$

Although we have defined the double integral  $\iint_R f(x, y) \, dA$  in terms of ordinary rectangles, it can be shown that, for continuous functions  $f$ , we always obtain the same answer using polar rectangles. The rectangular coordinates of the center of  $R_{ij}$  are  $(r_i^* \cos \theta_j^*, r_i^* \sin \theta_j^*)$ , so a typical Riemann sum is

$$\boxed{1} \quad \sum_{i=1}^m \sum_{j=1}^n f(r_i^* \cos \theta_j^*, r_i^* \sin \theta_j^*) \Delta A_i = \sum_{i=1}^m \sum_{j=1}^n f(r_i^* \cos \theta_j^*, r_i^* \sin \theta_j^*) r_i^* \Delta r \Delta\theta$$

If we write  $g(r, \theta) = rf(r \cos \theta, r \sin \theta)$ , then the Riemann sum in Equation 1 can be written as

$$\sum_{i=1}^m \sum_{j=1}^n g(r_i^*, \theta_j^*) \Delta r \Delta\theta$$

which is a Riemann sum for the double integral

$$\int_{\alpha}^{\beta} \int_a^b g(r, \theta) dr d\theta$$

Therefore we have

$$\begin{aligned} \iint_R f(x, y) dA &= \lim_{m, n \rightarrow \infty} \sum_{i=1}^m \sum_{j=1}^n f(r_i^* \cos \theta_j^*, r_i^* \sin \theta_j^*) \Delta A_i \\ &= \lim_{m, n \rightarrow \infty} \sum_{i=1}^m \sum_{j=1}^n g(r_i^*, \theta_j^*) \Delta r \Delta \theta = \int_{\alpha}^{\beta} \int_a^b g(r, \theta) dr d\theta \\ &= \int_{\alpha}^{\beta} \int_a^b f(r \cos \theta, r \sin \theta) r dr d\theta \end{aligned}$$

**2 Change to Polar Coordinates in a Double Integral** If  $f$  is continuous on a polar rectangle  $R$  given by  $0 \leq a \leq r \leq b$ ,  $\alpha \leq \theta \leq \beta$ , where  $0 \leq \beta - \alpha \leq 2\pi$ , then

$$\iint_R f(x, y) dA = \int_{\alpha}^{\beta} \int_a^b f(r \cos \theta, r \sin \theta) r dr d\theta$$

The formula in [2] says that we convert from rectangular to polar coordinates in a double integral by writing  $x = r \cos \theta$  and  $y = r \sin \theta$ , using the appropriate limits of integration for  $r$  and  $\theta$ , and replacing  $dA$  by  $r dr d\theta$ . **Be careful not to forget the additional factor  $r$  on the right side of Formula 2.** A classical method for remembering this is shown in Figure 5, where the “infinitesimal” polar rectangle can be thought of as an ordinary rectangle with dimensions  $r d\theta$  and  $dr$  and therefore has “area”  $dA = r dr d\theta$ .

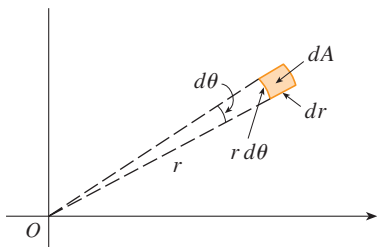


FIGURE 5

**EXAMPLE 1** Evaluate  $\iint_R (3x + 4y^2) dA$ , where  $R$  is the region in the upper half-plane bounded by the circles  $x^2 + y^2 = 1$  and  $x^2 + y^2 = 4$ .

**SOLUTION** The region  $R$  can be described as

$$R = \{(x, y) \mid y \geq 0, 1 \leq x^2 + y^2 \leq 4\}$$

It is the half-ring shown in Figure 1(b), and in polar coordinates it is given by  $1 \leq r \leq 2$ ,  $0 \leq \theta \leq \pi$ . Therefore, by Formula 2,

$$\begin{aligned} \iint_R (3x + 4y^2) dA &= \int_0^{\pi} \int_1^2 (3r \cos \theta + 4r^2 \sin^2 \theta) r dr d\theta \\ &= \int_0^{\pi} \int_1^2 (3r^2 \cos \theta + 4r^3 \sin^2 \theta) dr d\theta \\ &= \int_0^{\pi} [r^3 \cos \theta + r^4 \sin^2 \theta]_{r=1}^{r=2} d\theta = \int_0^{\pi} (7 \cos \theta + 15 \sin^2 \theta) d\theta \\ &= \int_0^{\pi} \left[ 7 \cos \theta + \frac{15}{2} (1 - \cos 2\theta) \right] d\theta \\ &= \left[ 7 \sin \theta + \frac{15\theta}{2} - \frac{15}{4} \sin 2\theta \right]_0^{\pi} = \frac{15\pi}{2} \end{aligned}$$

Here we use the trigonometric identity

$$\sin^2 \theta = \frac{1}{2}(1 - \cos 2\theta)$$

See Section 7.2 for advice on integrating trigonometric functions.

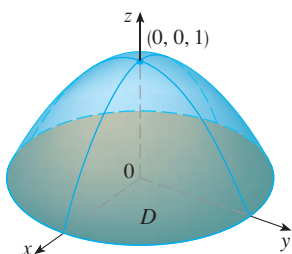


FIGURE 6

**V EXAMPLE 2** Find the volume of the solid bounded by the plane  $z = 0$  and the paraboloid  $z = 1 - x^2 - y^2$ .

**SOLUTION** If we put  $z = 0$  in the equation of the paraboloid, we get  $x^2 + y^2 = 1$ . This means that the plane intersects the paraboloid in the circle  $x^2 + y^2 = 1$ , so the solid lies under the paraboloid and above the circular disk  $D$  given by  $x^2 + y^2 \leq 1$  [see Figures 6 and 1(a)]. In polar coordinates  $D$  is given by  $0 \leq r \leq 1$ ,  $0 \leq \theta \leq 2\pi$ . Since  $1 - x^2 - y^2 = 1 - r^2$ , the volume is

$$\begin{aligned} V &= \iint_D (1 - x^2 - y^2) dA = \int_0^{2\pi} \int_0^1 (1 - r^2) r dr d\theta \\ &= \int_0^{2\pi} d\theta \int_0^1 (r - r^3) dr = 2\pi \left[ \frac{r^2}{2} - \frac{r^4}{4} \right]_0^1 = \frac{\pi}{2} \end{aligned}$$

If we had used rectangular coordinates instead of polar coordinates, then we would have obtained

$$V = \iint_D (1 - x^2 - y^2) dA = \int_{-1}^1 \int_{-\sqrt{1-x^2}}^{\sqrt{1-x^2}} (1 - x^2 - y^2) dy dx$$

which is not easy to evaluate because it involves finding  $\int (1 - x^2)^{3/2} dx$ .  

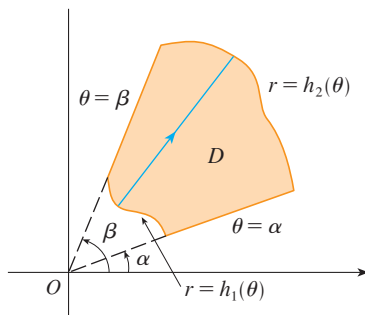


FIGURE 7

$$D = \{(r, \theta) \mid \alpha \leq \theta \leq \beta, h_1(\theta) \leq r \leq h_2(\theta)\}$$

What we have done so far can be extended to the more complicated type of region shown in Figure 7. It's similar to the type II rectangular regions considered in Section 15.3. In fact, by combining Formula 2 in this section with Formula 15.3.5, we obtain the following formula.

**3** If  $f$  is continuous on a polar region of the form

$$D = \{(r, \theta) \mid \alpha \leq \theta \leq \beta, h_1(\theta) \leq r \leq h_2(\theta)\}$$

$$\text{then} \quad \iint_D f(x, y) dA = \int_{\alpha}^{\beta} \int_{h_1(\theta)}^{h_2(\theta)} f(r \cos \theta, r \sin \theta) r dr d\theta$$

In particular, taking  $f(x, y) = 1$ ,  $h_1(\theta) = 0$ , and  $h_2(\theta) = h(\theta)$  in this formula, we see that the area of the region  $D$  bounded by  $\theta = \alpha$ ,  $\theta = \beta$ , and  $r = h(\theta)$  is

$$\begin{aligned} A(D) &= \iint_D 1 dA = \int_{\alpha}^{\beta} \int_0^{h(\theta)} r dr d\theta \\ &= \int_{\alpha}^{\beta} \left[ \frac{r^2}{2} \right]_0^{h(\theta)} d\theta = \int_{\alpha}^{\beta} \frac{1}{2} [h(\theta)]^2 d\theta \end{aligned}$$

and this agrees with Formula 10.4.3.

**V EXAMPLE 3** Use a double integral to find the area enclosed by one loop of the four-leaved rose  $r = \cos 2\theta$ .

**SOLUTION** From the sketch of the curve in Figure 8, we see that a loop is given by the region

$$D = \{(r, \theta) \mid -\pi/4 \leq \theta \leq \pi/4, 0 \leq r \leq \cos 2\theta\}$$

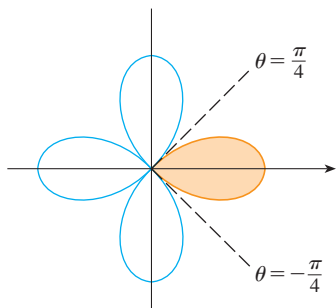


FIGURE 8

So the area is

$$\begin{aligned} A(D) &= \iint_D dA = \int_{-\pi/4}^{\pi/4} \int_0^{\cos 2\theta} r \, dr \, d\theta \\ &= \int_{-\pi/4}^{\pi/4} \left[ \frac{1}{2} r^2 \right]_0^{\cos 2\theta} d\theta = \frac{1}{2} \int_{-\pi/4}^{\pi/4} \cos^2 2\theta \, d\theta \\ &= \frac{1}{4} \int_{-\pi/4}^{\pi/4} (1 + \cos 4\theta) \, d\theta = \frac{1}{4} \left[ \theta + \frac{1}{4} \sin 4\theta \right]_{-\pi/4}^{\pi/4} = \frac{\pi}{8} \end{aligned}$$

**V EXAMPLE 4** Find the volume of the solid that lies under the paraboloid  $z = x^2 + y^2$ , above the  $xy$ -plane, and inside the cylinder  $x^2 + y^2 = 2x$ .

**SOLUTION** The solid lies above the disk  $D$  whose boundary circle has equation  $x^2 + y^2 = 2x$  or, after completing the square,

$$(x - 1)^2 + y^2 = 1$$

(See Figures 9 and 10.)

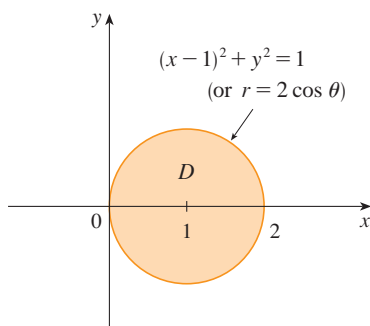


FIGURE 9

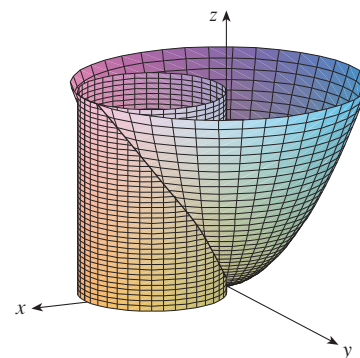


FIGURE 10

In polar coordinates we have  $x^2 + y^2 = r^2$  and  $x = r \cos \theta$ , so the boundary circle becomes  $r^2 = 2r \cos \theta$ , or  $r = 2 \cos \theta$ . Thus the disk  $D$  is given by

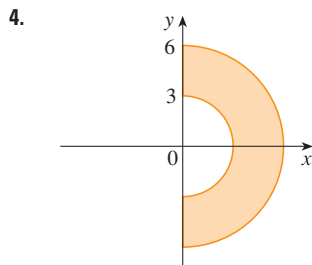
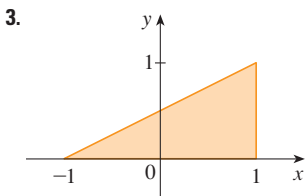
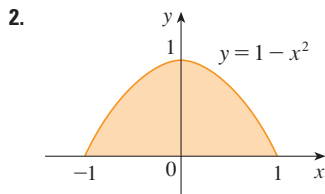
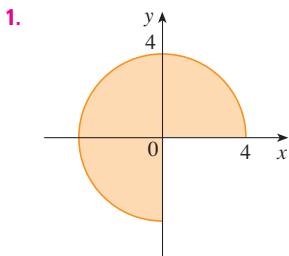
$$D = \{(r, \theta) \mid -\pi/2 \leq \theta \leq \pi/2, 0 \leq r \leq 2 \cos \theta\}$$

and, by Formula 3, we have

$$\begin{aligned} V &= \iint_D (x^2 + y^2) \, dA = \int_{-\pi/2}^{\pi/2} \int_0^{2 \cos \theta} r^2 \, r \, dr \, d\theta = \int_{-\pi/2}^{\pi/2} \left[ \frac{r^4}{4} \right]_0^{2 \cos \theta} d\theta \\ &= 4 \int_{-\pi/2}^{\pi/2} \cos^4 \theta \, d\theta = 8 \int_0^{\pi/2} \cos^4 \theta \, d\theta = 8 \int_0^{\pi/2} \left( \frac{1 + \cos 2\theta}{2} \right)^2 d\theta \\ &= 2 \int_0^{\pi/2} \left[ 1 + 2 \cos 2\theta + \frac{1}{2}(1 + \cos 4\theta) \right] d\theta \\ &= 2 \left[ \frac{3}{2} \theta + \sin 2\theta + \frac{1}{8} \sin 4\theta \right]_0^{\pi/2} = 2 \left( \frac{3}{2} \right) \left( \frac{\pi}{2} \right) = \frac{3\pi}{2} \end{aligned}$$

## 15.4 Exercises

1–4 A region  $R$  is shown. Decide whether to use polar coordinates or rectangular coordinates and write  $\iint_R f(x, y) dA$  as an iterated integral, where  $f$  is an arbitrary continuous function on  $R$ .



5–6 Sketch the region whose area is given by the integral and evaluate the integral.

5.  $\int_{\pi/4}^{3\pi/4} \int_1^2 r dr d\theta$

6.  $\int_{\pi/2}^{\pi} \int_0^{2 \sin \theta} r dr d\theta$

7–14 Evaluate the given integral by changing to polar coordinates.

7.  $\iint_D x^2 y dA$ , where  $D$  is the top half of the disk with center the origin and radius 5

8.  $\iint_R (2x - y) dA$ , where  $R$  is the region in the first quadrant enclosed by the circle  $x^2 + y^2 = 4$  and the lines  $x = 0$  and  $y = x$

9.  $\iint_R \sin(x^2 + y^2) dA$ , where  $R$  is the region in the first quadrant between the circles with center the origin and radii 1 and 3

10.  $\iint_R \frac{y^2}{x^2 + y^2} dA$ , where  $R$  is the region that lies between the circles  $x^2 + y^2 = a^2$  and  $x^2 + y^2 = b^2$  with  $0 < a < b$

11.  $\iint_D e^{-x^2 - y^2} dA$ , where  $D$  is the region bounded by the semicircle  $x = \sqrt{4 - y^2}$  and the  $y$ -axis

12.  $\iint_D \cos \sqrt{x^2 + y^2} dA$ , where  $D$  is the disk with center the origin and radius 2

13.  $\iint_R \arctan(y/x) dA$ , where  $R = \{(x, y) \mid 1 \leq x^2 + y^2 \leq 4, 0 \leq y \leq x\}$

14.  $\iint_D x dA$ , where  $D$  is the region in the first quadrant that lies between the circles  $x^2 + y^2 = 4$  and  $x^2 + y^2 = 2x$

15–18 Use a double integral to find the area of the region.

15. One loop of the rose  $r = \cos 3\theta$

16. The region enclosed by both of the cardioids  $r = 1 + \cos \theta$  and  $r = 1 - \cos \theta$

17. The region inside the circle  $(x - 1)^2 + y^2 = 1$  and outside the circle  $x^2 + y^2 = 1$

18. The region inside the cardioid  $r = 1 + \cos \theta$  and outside the circle  $r = 3 \cos \theta$

19–27 Use polar coordinates to find the volume of the given solid.

19. Under the cone  $z = \sqrt{x^2 + y^2}$  and above the disk  $x^2 + y^2 \leq 4$

20. Below the paraboloid  $z = 18 - 2x^2 - 2y^2$  and above the  $xy$ -plane

21. Enclosed by the hyperboloid  $-x^2 - y^2 + z^2 = 1$  and the plane  $z = 2$

22. Inside the sphere  $x^2 + y^2 + z^2 = 16$  and outside the cylinder  $x^2 + y^2 = 4$

23. A sphere of radius  $a$

24. Bounded by the paraboloid  $z = 1 + 2x^2 + 2y^2$  and the plane  $z = 7$  in the first octant

25. Above the cone  $z = \sqrt{x^2 + y^2}$  and below the sphere  $x^2 + y^2 + z^2 = 1$

26. Bounded by the paraboloids  $z = 3x^2 + 3y^2$  and  $z = 4 - x^2 - y^2$

27. Inside both the cylinder  $x^2 + y^2 = 4$  and the ellipsoid  $4x^2 + 4y^2 + z^2 = 64$

28. (a) A cylindrical drill with radius  $r_1$  is used to bore a hole through the center of a sphere of radius  $r_2$ . Find the volume of the ring-shaped solid that remains.

(b) Express the volume in part (a) in terms of the height  $h$  of the ring. Notice that the volume depends only on  $h$ , not on  $r_1$  or  $r_2$ .

29–32 Evaluate the iterated integral by converting to polar coordinates.

29.  $\int_{-3}^3 \int_0^{\sqrt{9-x^2}} \sin(x^2 + y^2) dy dx$

30.  $\int_0^a \int_{-\sqrt{a^2-y^2}}^0 x^2 y dx dy$

31.  $\int_0^1 \int_y^{\sqrt{2-y^2}} (x + y) dx dy$

32.  $\int_0^2 \int_0^{\sqrt{2x-x^2}} \sqrt{x^2 + y^2} dy dx$

**33–34** Express the double integral in terms of a single integral with respect to  $r$ . Then use your calculator to evaluate the integral correct to four decimal places.

**33.**  $\iint_D e^{(x^2+y^2)^2} dA$ , where  $D$  is the disk with center the origin and radius 1

**34.**  $\iint_D xy\sqrt{1+x^2+y^2} dA$ , where  $D$  is the portion of the disk  $x^2+y^2 \leq 1$  that lies in the first quadrant

**35.** A swimming pool is circular with a 40-ft diameter. The depth is constant along east-west lines and increases linearly from 2 ft at the south end to 7 ft at the north end. Find the volume of water in the pool.

**36.** An agricultural sprinkler distributes water in a circular pattern of radius 100 ft. It supplies water to a depth of  $e^{-r}$  feet per hour at a distance of  $r$  feet from the sprinkler.

(a) If  $0 < R \leq 100$ , what is the total amount of water supplied per hour to the region inside the circle of radius  $R$  centered at the sprinkler?

(b) Determine an expression for the average amount of water per hour per square foot supplied to the region inside the circle of radius  $R$ .

**37.** Find the average value of the function  $f(x, y) = 1/\sqrt{x^2 + y^2}$  on the annular region  $a^2 \leq x^2 + y^2 \leq b^2$ , where  $0 < a < b$ .

**38.** Let  $D$  be the disk with center the origin and radius  $a$ . What is the average distance from points in  $D$  to the origin?

**39.** Use polar coordinates to combine the sum

$$\int_{1/\sqrt{2}}^1 \int_{\sqrt{1-x^2}}^x xy dy dx + \int_1^{\sqrt{2}} \int_0^x xy dy dx + \int_{\sqrt{2}}^2 \int_0^{\sqrt{4-x^2}} xy dy dx$$

into one double integral. Then evaluate the double integral.

**40.** (a) We define the improper integral (over the entire plane  $\mathbb{R}^2$ )

$$\begin{aligned} I &= \iint_{\mathbb{R}^2} e^{-(x^2+y^2)} dA = \int_{-\infty}^{\infty} \int_{-\infty}^{\infty} e^{-(x^2+y^2)} dy dx \\ &= \lim_{a \rightarrow \infty} \iint_{D_a} e^{-(x^2+y^2)} dA \end{aligned}$$

where  $D_a$  is the disk with radius  $a$  and center the origin. Show that

$$\int_{-\infty}^{\infty} \int_{-\infty}^{\infty} e^{-(x^2+y^2)} dA = \pi$$

(b) An equivalent definition of the improper integral in part (a) is

$$\iint_{\mathbb{R}^2} e^{-(x^2+y^2)} dA = \lim_{a \rightarrow \infty} \iint_{S_a} e^{-(x^2+y^2)} dA$$

where  $S_a$  is the square with vertices  $(\pm a, \pm a)$ . Use this to show that

$$\int_{-\infty}^{\infty} e^{-x^2} dx \int_{-\infty}^{\infty} e^{-y^2} dy = \pi$$

(c) Deduce that

$$\int_{-\infty}^{\infty} e^{-x^2} dx = \sqrt{\pi}$$

(d) By making the change of variable  $t = \sqrt{2}x$ , show that

$$\int_{-\infty}^{\infty} e^{-x^2/2} dx = \sqrt{2\pi}$$

(This is a fundamental result for probability and statistics.)

**41.** Use the result of Exercise 40 part (c) to evaluate the following integrals.

(a)  $\int_0^{\infty} x^2 e^{-x^2} dx$       (b)  $\int_0^{\infty} \sqrt{x} e^{-x} dx$

## 15.5 Applications of Double Integrals

We have already seen one application of double integrals: computing volumes. Another geometric application is finding areas of surfaces and this will be done in the next section. In this section we explore physical applications such as computing mass, electric charge, center of mass, and moment of inertia. We will see that these physical ideas are also important when applied to probability density functions of two random variables.

### Density and Mass

In Section 8.3 we were able to use single integrals to compute moments and the center of mass of a thin plate or lamina with constant density. But now, equipped with the double integral, we can consider a lamina with variable density. Suppose the lamina occupies a region  $D$  of the  $xy$ -plane and its **density** (in units of mass per unit area) at a point  $(x, y)$  in  $D$  is given by  $\rho(x, y)$ , where  $\rho$  is a continuous function on  $D$ . This means that

$$\rho(x, y) = \lim \frac{\Delta m}{\Delta A}$$

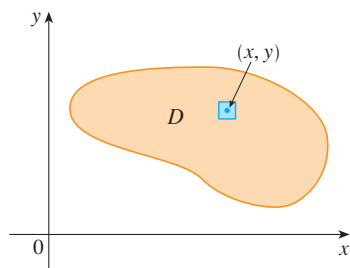


FIGURE 1

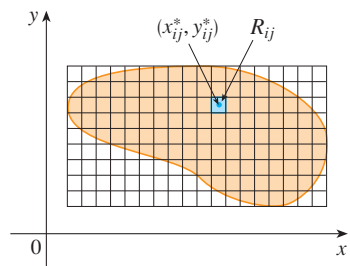


FIGURE 2

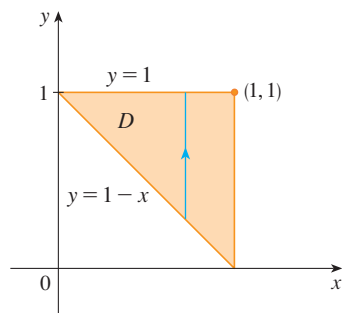


FIGURE 3

where  $\Delta m$  and  $\Delta A$  are the mass and area of a small rectangle that contains  $(x, y)$  and the limit is taken as the dimensions of the rectangle approach 0. (See Figure 1.)

To find the total mass  $m$  of the lamina we divide a rectangle  $R$  containing  $D$  into subrectangles  $R_{ij}$  of the same size (as in Figure 2) and consider  $\rho(x, y)$  to be 0 outside  $D$ . If we choose a point  $(x_{ij}^*, y_{ij}^*)$  in  $R_{ij}$ , then the mass of the part of the lamina that occupies  $R_{ij}$  is approximately  $\rho(x_{ij}^*, y_{ij}^*) \Delta A$ , where  $\Delta A$  is the area of  $R_{ij}$ . If we add all such masses, we get an approximation to the total mass:

$$m \approx \sum_{i=1}^k \sum_{j=1}^l \rho(x_{ij}^*, y_{ij}^*) \Delta A$$

If we now increase the number of subrectangles, we obtain the total mass  $m$  of the lamina as the limiting value of the approximations:

$$\boxed{1} \quad m = \lim_{k, l \rightarrow \infty} \sum_{i=1}^k \sum_{j=1}^l \rho(x_{ij}^*, y_{ij}^*) \Delta A = \iint_D \rho(x, y) \, dA$$

Physicists also consider other types of density that can be treated in the same manner. For example, if an electric charge is distributed over a region  $D$  and the charge density (in units of charge per unit area) is given by  $\sigma(x, y)$  at a point  $(x, y)$  in  $D$ , then the total charge  $Q$  is given by

$$\boxed{2} \quad Q = \iint_D \sigma(x, y) \, dA$$

**EXAMPLE 1** Charge is distributed over the triangular region  $D$  in Figure 3 so that the charge density at  $(x, y)$  is  $\sigma(x, y) = xy$ , measured in coulombs per square meter ( $\text{C}/\text{m}^2$ ). Find the total charge.

**SOLUTION** From Equation 2 and Figure 3 we have

$$\begin{aligned} Q &= \iint_D \sigma(x, y) \, dA = \int_0^1 \int_{1-x}^1 xy \, dy \, dx \\ &= \int_0^1 \left[ x \frac{y^2}{2} \right]_{y=1-x}^{y=1} dx = \int_0^1 \frac{x}{2} [1^2 - (1-x)^2] dx \\ &= \frac{1}{2} \int_0^1 (2x^2 - x^3) dx = \frac{1}{2} \left[ \frac{2x^3}{3} - \frac{x^4}{4} \right]_0^1 = \frac{5}{24} \end{aligned}$$

Thus the total charge is  $\frac{5}{24}$  C.

### Moments and Centers of Mass

In Section 8.3 we found the center of mass of a lamina with constant density; here we consider a lamina with variable density. Suppose the lamina occupies a region  $D$  and has density function  $\rho(x, y)$ . Recall from Chapter 8 that we defined the moment of a particle about an axis as the product of its mass and its directed distance from the axis. We divide  $D$  into small rectangles as in Figure 2. Then the mass of  $R_{ij}$  is approximately  $\rho(x_{ij}^*, y_{ij}^*) \Delta A$ , so we can approximate the moment of  $R_{ij}$  with respect to the  $x$ -axis by

$$[\rho(x_{ij}^*, y_{ij}^*) \Delta A] y_{ij}^*$$

If we now add these quantities and take the limit as the number of subrectangles becomes



large, we obtain the **moment** of the entire lamina **about the  $x$ -axis**:

$$3 \quad M_x = \lim_{m, n \rightarrow \infty} \sum_{i=1}^m \sum_{j=1}^n y_{ij}^* \rho(x_{ij}^*, y_{ij}^*) \Delta A = \iint_D y \rho(x, y) dA$$

Similarly, the **moment about the  $y$ -axis** is

$$4 \quad M_y = \lim_{m, n \rightarrow \infty} \sum_{i=1}^m \sum_{j=1}^n x_{ij}^* \rho(x_{ij}^*, y_{ij}^*) \Delta A = \iint_D x \rho(x, y) dA$$

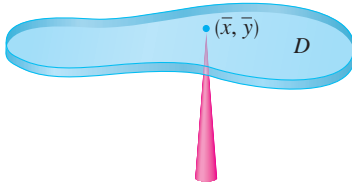


FIGURE 4

As before, we define the center of mass  $(\bar{x}, \bar{y})$  so that  $m\bar{x} = M_y$  and  $m\bar{y} = M_x$ . The physical significance is that the lamina behaves as if its entire mass is concentrated at its center of mass. Thus the lamina balances horizontally when supported at its center of mass (see Figure 4).

5 The coordinates  $(\bar{x}, \bar{y})$  of the center of mass of a lamina occupying the region  $D$  and having density function  $\rho(x, y)$  are

$$\bar{x} = \frac{M_y}{m} = \frac{1}{m} \iint_D x \rho(x, y) dA \quad \bar{y} = \frac{M_x}{m} = \frac{1}{m} \iint_D y \rho(x, y) dA$$

where the mass  $m$  is given by

$$m = \iint_D \rho(x, y) dA$$

**V EXAMPLE 2** Find the mass and center of mass of a triangular lamina with vertices  $(0, 0)$ ,  $(1, 0)$ , and  $(0, 2)$  if the density function is  $\rho(x, y) = 1 + 3x + y$ .

**SOLUTION** The triangle is shown in Figure 5. (Note that the equation of the upper boundary is  $y = 2 - 2x$ .) The mass of the lamina is

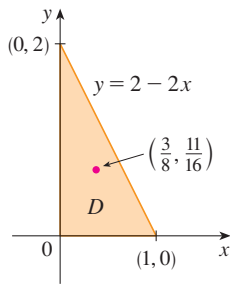


FIGURE 5

$$\begin{aligned} m &= \iint_D \rho(x, y) dA = \int_0^1 \int_0^{2-2x} (1 + 3x + y) dy dx \\ &= \int_0^1 \left[ y + 3xy + \frac{y^2}{2} \right]_{y=0}^{y=2-2x} dx \\ &= 4 \int_0^1 (1 - x^2) dx = 4 \left[ x - \frac{x^3}{3} \right]_0^1 = \frac{8}{3} \end{aligned}$$

Then the formulas in [5] give

$$\begin{aligned} \bar{x} &= \frac{1}{m} \iint_D x \rho(x, y) dA = \frac{3}{8} \int_0^1 \int_0^{2-2x} (x + 3x^2 + xy) dy dx \\ &= \frac{3}{8} \int_0^1 \left[ xy + 3x^2y + x \frac{y^2}{2} \right]_{y=0}^{y=2-2x} dx \\ &= \frac{3}{2} \int_0^1 (x - x^3) dx = \frac{3}{2} \left[ \frac{x^2}{2} - \frac{x^4}{4} \right]_0^1 = \frac{3}{8} \end{aligned}$$

$$\begin{aligned}
 \bar{y} &= \frac{1}{m} \iint_D y \rho(x, y) \, dA = \frac{3}{8} \int_0^1 \int_0^{2-2x} (y + 3xy + y^2) \, dy \, dx \\
 &= \frac{3}{8} \int_0^1 \left[ \frac{y^2}{2} + 3x \frac{y^2}{2} + \frac{y^3}{3} \right]_{y=0}^{y=2-2x} dx = \frac{1}{4} \int_0^1 (7 - 9x - 3x^2 + 5x^3) \, dx \\
 &= \frac{1}{4} \left[ 7x - 9 \frac{x^2}{2} - x^3 + 5 \frac{x^4}{4} \right]_0^1 = \frac{11}{16}
 \end{aligned}$$

The center of mass is at the point  $(\frac{3}{8}, \frac{11}{16})$ .

**V EXAMPLE 3** The density at any point on a semicircular lamina is proportional to the distance from the center of the circle. Find the center of mass of the lamina.

**SOLUTION** Let's place the lamina as the upper half of the circle  $x^2 + y^2 = a^2$ . (See Figure 6.) Then the distance from a point  $(x, y)$  to the center of the circle (the origin) is  $\sqrt{x^2 + y^2}$ . Therefore the density function is

$$\rho(x, y) = K\sqrt{x^2 + y^2}$$

where  $K$  is some constant. Both the density function and the shape of the lamina suggest that we convert to polar coordinates. Then  $\sqrt{x^2 + y^2} = r$  and the region  $D$  is given by  $0 \leq r \leq a$ ,  $0 \leq \theta \leq \pi$ . Thus the mass of the lamina is

$$\begin{aligned}
 m &= \iint_D \rho(x, y) \, dA = \iint_D K\sqrt{x^2 + y^2} \, dA \\
 &= \int_0^\pi \int_0^a (Kr) \, r \, dr \, d\theta = K \int_0^\pi d\theta \int_0^a r^2 \, dr \\
 &= K\pi \left[ \frac{r^3}{3} \right]_0^a = \frac{K\pi a^3}{3}
 \end{aligned}$$

Both the lamina and the density function are symmetric with respect to the  $y$ -axis, so the center of mass must lie on the  $y$ -axis, that is,  $\bar{x} = 0$ . The  $y$ -coordinate is given by

$$\begin{aligned}
 \bar{y} &= \frac{1}{m} \iint_D y \rho(x, y) \, dA = \frac{3}{K\pi a^3} \int_0^\pi \int_0^a r \sin \theta (Kr) \, r \, dr \, d\theta \\
 &= \frac{3}{\pi a^3} \int_0^\pi \sin \theta \, d\theta \int_0^a r^3 \, dr = \frac{3}{\pi a^3} [-\cos \theta]_0^\pi \left[ \frac{r^4}{4} \right]_0^a \\
 &= \frac{3}{\pi a^3} \frac{2a^4}{4} = \frac{3a}{2\pi}
 \end{aligned}$$

Therefore the center of mass is located at the point  $(0, 3a/(2\pi))$ .

### Moment of Inertia

The **moment of inertia** (also called the **second moment**) of a particle of mass  $m$  about an axis is defined to be  $mr^2$ , where  $r$  is the distance from the particle to the axis. We extend this concept to a lamina with density function  $\rho(x, y)$  and occupying a region  $D$  by proceeding as we did for ordinary moments. We divide  $D$  into small rectangles, approximate the moment of inertia of each subrectangle about the  $x$ -axis, and take the limit of the sum

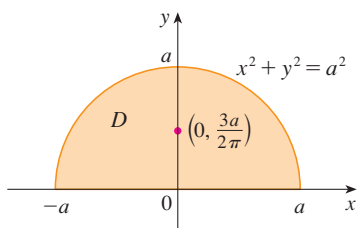


FIGURE 6

Compare the location of the center of mass in Example 3 with Example 4 in Section 8.3, where we found that the center of mass of a lamina with the same shape but uniform density is located at the point  $(0, 4a/(3\pi))$ .

as the number of subrectangles becomes large. The result is the **moment of inertia** of the lamina **about the x-axis**:

$$I_x = \lim_{m, n \rightarrow \infty} \sum_{i=1}^m \sum_{j=1}^n (y_{ij}^*)^2 \rho(x_{ij}^*, y_{ij}^*) \Delta A = \iint_D y^2 \rho(x, y) dA$$

Similarly, the **moment of inertia about the y-axis** is

$$I_y = \lim_{m, n \rightarrow \infty} \sum_{i=1}^m \sum_{j=1}^n (x_{ij}^*)^2 \rho(x_{ij}^*, y_{ij}^*) \Delta A = \iint_D x^2 \rho(x, y) dA$$

It is also of interest to consider the **moment of inertia about the origin**, also called the **polar moment of inertia**:

$$I_0 = \lim_{m, n \rightarrow \infty} \sum_{i=1}^m \sum_{j=1}^n [(x_{ij}^*)^2 + (y_{ij}^*)^2] \rho(x_{ij}^*, y_{ij}^*) \Delta A = \iint_D (x^2 + y^2) \rho(x, y) dA$$

Note that  $I_0 = I_x + I_y$ .

**V EXAMPLE 4** Find the moments of inertia  $I_x$ ,  $I_y$ , and  $I_0$  of a homogeneous disk  $D$  with density  $\rho(x, y) = \rho$ , center the origin, and radius  $a$ .

**SOLUTION** The boundary of  $D$  is the circle  $x^2 + y^2 = a^2$  and in polar coordinates  $D$  is described by  $0 \leq \theta \leq 2\pi$ ,  $0 \leq r \leq a$ . Let's compute  $I_0$  first:

$$\begin{aligned} I_0 &= \iint_D (x^2 + y^2) \rho dA = \rho \int_0^{2\pi} \int_0^a r^2 r dr d\theta \\ &= \rho \int_0^{2\pi} d\theta \int_0^a r^3 dr = 2\pi\rho \left[ \frac{r^4}{4} \right]_0^a = \frac{\pi\rho a^4}{2} \end{aligned}$$

Instead of computing  $I_x$  and  $I_y$  directly, we use the facts that  $I_x + I_y = I_0$  and  $I_x = I_y$  (from the symmetry of the problem). Thus

$$I_x = I_y = \frac{I_0}{2} = \frac{\pi\rho a^4}{4}$$

In Example 4 notice that the mass of the disk is

$$m = \text{density} \times \text{area} = \rho(\pi a^2)$$

so the moment of inertia of the disk about the origin (like a wheel about its axle) can be written as

$$I_0 = \frac{\pi\rho a^4}{2} = \frac{1}{2}(\rho\pi a^2)a^2 = \frac{1}{2}ma^2$$

Thus if we increase the mass or the radius of the disk, we thereby increase the moment of inertia. In general, the moment of inertia plays much the same role in rotational motion

that mass plays in linear motion. The moment of inertia of a wheel is what makes it difficult to start or stop the rotation of the wheel, just as the mass of a car is what makes it difficult to start or stop the motion of the car.

The **radius of gyration of a lamina about an axis** is the number  $R$  such that

$$\boxed{9} \quad mR^2 = I$$

where  $m$  is the mass of the lamina and  $I$  is the moment of inertia about the given axis. Equation 9 says that if the mass of the lamina were concentrated at a distance  $R$  from the axis, then the moment of inertia of this “point mass” would be the same as the moment of inertia of the lamina.

In particular, the radius of gyration  $\bar{y}$  with respect to the  $x$ -axis and the radius of gyration  $\bar{x}$  with respect to the  $y$ -axis are given by the equations

$$\boxed{10} \quad m\bar{y}^2 = I_x \quad m\bar{x}^2 = I_y$$

Thus  $(\bar{x}, \bar{y})$  is the point at which the mass of the lamina can be concentrated without changing the moments of inertia with respect to the coordinate axes. (Note the analogy with the center of mass.)

**V EXAMPLE 5** Find the radius of gyration about the  $x$ -axis of the disk in Example 4.

**SOLUTION** As noted, the mass of the disk is  $m = \rho\pi a^2$ , so from Equations 10 we have

$$\bar{y}^2 = \frac{I_x}{m} = \frac{\frac{1}{4}\pi\rho a^4}{\rho\pi a^2} = \frac{a^2}{4}$$

Therefore the radius of gyration about the  $x$ -axis is  $\bar{y} = \frac{1}{2}a$ , which is half the radius of the disk. ■

## Probability

In Section 8.5 we considered the *probability density function*  $f$  of a continuous random variable  $X$ . This means that  $f(x) \geq 0$  for all  $x$ ,  $\int_{-\infty}^{\infty} f(x) dx = 1$ , and the probability that  $X$  lies between  $a$  and  $b$  is found by integrating  $f$  from  $a$  to  $b$ :

$$P(a \leq X \leq b) = \int_a^b f(x) dx$$

Now we consider a pair of continuous random variables  $X$  and  $Y$ , such as the lifetimes of two components of a machine or the height and weight of an adult female chosen at random. The **joint density function** of  $X$  and  $Y$  is a function  $f$  of two variables such that the probability that  $(X, Y)$  lies in a region  $D$  is

$$P((X, Y) \in D) = \iint_D f(x, y) dA$$

In particular, if the region is a rectangle, the probability that  $X$  lies between  $a$  and  $b$  and  $Y$  lies between  $c$  and  $d$  is

$$P(a \leq X \leq b, c \leq Y \leq d) = \int_a^b \int_c^d f(x, y) dy dx$$

(See Figure 7.)

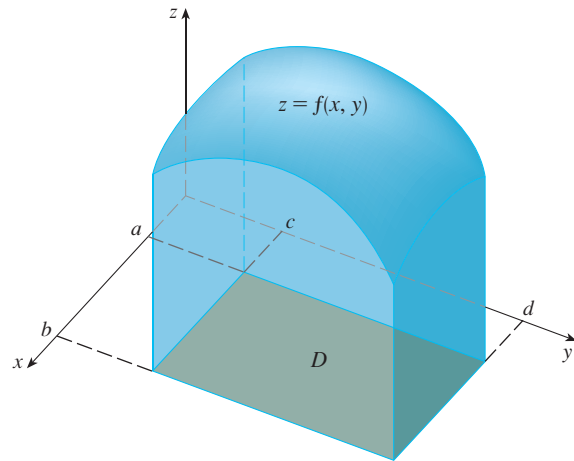


FIGURE 7

The probability that  $X$  lies between  $a$  and  $b$  and  $Y$  lies between  $c$  and  $d$  is the volume that lies above the rectangle  $D = [a, b] \times [c, d]$  and below the graph of the joint density function.

Because probabilities aren't negative and are measured on a scale from 0 to 1, the joint density function has the following properties:

$$f(x, y) \geq 0 \quad \iint_{\mathbb{R}^2} f(x, y) \, dA = 1$$

As in Exercise 40 in Section 15.4, the double integral over  $\mathbb{R}^2$  is an improper integral defined as the limit of double integrals over expanding circles or squares, and we can write

$$\iint_{\mathbb{R}^2} f(x, y) \, dA = \int_{-\infty}^{\infty} \int_{-\infty}^{\infty} f(x, y) \, dx \, dy = 1$$

**EXAMPLE 6** If the joint density function for  $X$  and  $Y$  is given by

$$f(x, y) = \begin{cases} C(x + 2y) & \text{if } 0 \leq x \leq 10, 0 \leq y \leq 10 \\ 0 & \text{otherwise} \end{cases}$$

find the value of the constant  $C$ . Then find  $P(X \leq 7, Y \geq 2)$ .

**SOLUTION** We find the value of  $C$  by ensuring that the double integral of  $f$  is equal to 1. Because  $f(x, y) = 0$  outside the rectangle  $[0, 10] \times [0, 10]$ , we have

$$\begin{aligned} \int_{-\infty}^{\infty} \int_{-\infty}^{\infty} f(x, y) \, dy \, dx &= \int_0^{10} \int_0^{10} C(x + 2y) \, dy \, dx = C \int_0^{10} [xy + y^2]_{y=0}^{y=10} \, dx \\ &= C \int_0^{10} (10x + 100) \, dx = 1500C \end{aligned}$$

Therefore  $1500C = 1$  and so  $C = \frac{1}{1500}$ .

Now we can compute the probability that  $X$  is at most 7 and  $Y$  is at least 2:

$$\begin{aligned} P(X \leq 7, Y \geq 2) &= \int_{-\infty}^7 \int_2^{\infty} f(x, y) \, dy \, dx = \int_0^7 \int_2^{10} \frac{1}{1500}(x + 2y) \, dy \, dx \\ &= \frac{1}{1500} \int_0^7 [xy + y^2]_{y=2}^{y=10} \, dx = \frac{1}{1500} \int_0^7 (8x + 96) \, dx \\ &= \frac{868}{1500} \approx 0.5787 \end{aligned}$$

Suppose  $X$  is a random variable with probability density function  $f_1(x)$  and  $Y$  is a random variable with density function  $f_2(y)$ . Then  $X$  and  $Y$  are called **independent random variables** if their joint density function is the product of their individual density functions:

$$f(x, y) = f_1(x)f_2(y)$$

In Section 8.5 we modeled waiting times by using exponential density functions

$$f(t) = \begin{cases} 0 & \text{if } t < 0 \\ \mu^{-1}e^{-t/\mu} & \text{if } t \geq 0 \end{cases}$$

where  $\mu$  is the mean waiting time. In the next example we consider a situation with two independent waiting times.

**EXAMPLE 7** The manager of a movie theater determines that the average time moviegoers wait in line to buy a ticket for this week's film is 10 minutes and the average time they wait to buy popcorn is 5 minutes. Assuming that the waiting times are independent, find the probability that a moviegoer waits a total of less than 20 minutes before taking his or her seat.

**SOLUTION** Assuming that both the waiting time  $X$  for the ticket purchase and the waiting time  $Y$  in the refreshment line are modeled by exponential probability density functions, we can write the individual density functions as

$$f_1(x) = \begin{cases} 0 & \text{if } x < 0 \\ \frac{1}{10}e^{-x/10} & \text{if } x \geq 0 \end{cases} \quad f_2(y) = \begin{cases} 0 & \text{if } y < 0 \\ \frac{1}{5}e^{-y/5} & \text{if } y \geq 0 \end{cases}$$

Since  $X$  and  $Y$  are independent, the joint density function is the product:

$$f(x, y) = f_1(x)f_2(y) = \begin{cases} \frac{1}{50}e^{-x/10}e^{-y/5} & \text{if } x \geq 0, y \geq 0 \\ 0 & \text{otherwise} \end{cases}$$

We are asked for the probability that  $X + Y < 20$ :

$$P(X + Y < 20) = P((X, Y) \in D)$$

where  $D$  is the triangular region shown in Figure 8. Thus

$$\begin{aligned} P(X + Y < 20) &= \iint_D f(x, y) \, dA = \int_0^{20} \int_0^{20-x} \frac{1}{50}e^{-x/10}e^{-y/5} \, dy \, dx \\ &= \frac{1}{50} \int_0^{20} \left[ e^{-x/10}(-5)e^{-y/5} \right]_{y=0}^{y=20-x} \, dx \\ &= \frac{1}{10} \int_0^{20} e^{-x/10}(1 - e^{-(x-20)/5}) \, dx \\ &= \frac{1}{10} \int_0^{20} (e^{-x/10} - e^{-4}e^{x/10}) \, dx \\ &= 1 + e^{-4} - 2e^{-2} \approx 0.7476 \end{aligned}$$

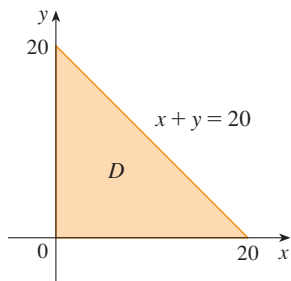


FIGURE 8

This means that about 75% of the moviegoers wait less than 20 minutes before taking their seats.

### Expected Values

Recall from Section 8.5 that if  $X$  is a random variable with probability density function  $f$ , then its *mean* is

$$\mu = \int_{-\infty}^{\infty} xf(x) dx$$

Now if  $X$  and  $Y$  are random variables with joint density function  $f$ , we define the **X-mean** and **Y-mean**, also called the **expected values** of  $X$  and  $Y$ , to be

$$\boxed{11} \quad \mu_1 = \iint_{\mathbb{R}^2} xf(x, y) dA \quad \mu_2 = \iint_{\mathbb{R}^2} yf(x, y) dA$$

Notice how closely the expressions for  $\mu_1$  and  $\mu_2$  in  $\boxed{11}$  resemble the moments  $M_x$  and  $M_y$  of a lamina with density function  $\rho$  in Equations 3 and 4. In fact, we can think of probability as being like continuously distributed mass. We calculate probability the way we calculate mass—by integrating a density function. And because the total “probability mass” is 1, the expressions for  $\bar{x}$  and  $\bar{y}$  in  $\boxed{5}$  show that we can think of the expected values of  $X$  and  $Y$ ,  $\mu_1$  and  $\mu_2$ , as the coordinates of the “center of mass” of the probability distribution.

In the next example we deal with normal distributions. As in Section 8.5, a single random variable is *normally distributed* if its probability density function is of the form

$$f(x) = \frac{1}{\sigma\sqrt{2\pi}} e^{-(x-\mu)^2/(2\sigma^2)}$$

where  $\mu$  is the mean and  $\sigma$  is the standard deviation.

**EXAMPLE 8** A factory produces (cylindrically shaped) roller bearings that are sold as having diameter 4.0 cm and length 6.0 cm. In fact, the diameters  $X$  are normally distributed with mean 4.0 cm and standard deviation 0.01 cm while the lengths  $Y$  are normally distributed with mean 6.0 cm and standard deviation 0.01 cm. Assuming that  $X$  and  $Y$  are independent, write the joint density function and graph it. Find the probability that a bearing randomly chosen from the production line has either length or diameter that differs from the mean by more than 0.02 cm.

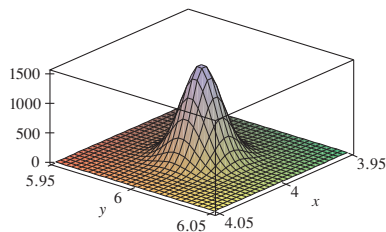
**SOLUTION** We are given that  $X$  and  $Y$  are normally distributed with  $\mu_1 = 4.0$ ,  $\mu_2 = 6.0$ , and  $\sigma_1 = \sigma_2 = 0.01$ . So the individual density functions for  $X$  and  $Y$  are

$$f_1(x) = \frac{1}{0.01\sqrt{2\pi}} e^{-(x-4)^2/0.0002} \quad f_2(y) = \frac{1}{0.01\sqrt{2\pi}} e^{-(y-6)^2/0.0002}$$

Since  $X$  and  $Y$  are independent, the joint density function is the product:

$$\begin{aligned} f(x, y) &= f_1(x)f_2(y) \\ &= \frac{1}{0.0002\pi} e^{-(x-4)^2/0.0002} e^{-(y-6)^2/0.0002} \\ &= \frac{5000}{\pi} e^{-5000[(x-4)^2+(y-6)^2]} \end{aligned}$$

A graph of this function is shown in Figure 9.



**FIGURE 9**  
Graph of the bivariate normal joint density function in Example 8

Let's first calculate the probability that both  $X$  and  $Y$  differ from their means by less than 0.02 cm. Using a calculator or computer to estimate the integral, we have

$$\begin{aligned} P(3.98 < X < 4.02, 5.98 < Y < 6.02) &= \int_{3.98}^{4.02} \int_{5.98}^{6.02} f(x, y) \, dy \, dx \\ &= \frac{5000}{\pi} \int_{3.98}^{4.02} \int_{5.98}^{6.02} e^{-5000[(x-4)^2 + (y-6)^2]} \, dy \, dx \\ &\approx 0.91 \end{aligned}$$

Then the probability that either  $X$  or  $Y$  differs from its mean by more than 0.02 cm is approximately

$$1 - 0.91 = 0.09$$

## 15.5 Exercises

- Electric charge is distributed over the rectangle  $0 \leq x \leq 5$ ,  $2 \leq y \leq 5$  so that the charge density at  $(x, y)$  is  $\sigma(x, y) = 2x + 4y$  (measured in coulombs per square meter). Find the total charge on the rectangle.
- Electric charge is distributed over the disk  $x^2 + y^2 \leq 1$  so that the charge density at  $(x, y)$  is  $\sigma(x, y) = \sqrt{x^2 + y^2}$  (measured in coulombs per square meter). Find the total charge on the disk.
- 10 Find the mass and center of mass of the lamina that occupies the region  $D$  and has the given density function  $\rho$ .
  - $D = \{(x, y) \mid 1 \leq x \leq 3, 1 \leq y \leq 4\}$ ;  $\rho(x, y) = ky^2$
  - $D = \{(x, y) \mid 0 \leq x \leq a, 0 \leq y \leq b\}$ ;  $\rho(x, y) = 1 + x^2 + y^2$
  - $D$  is the triangular region with vertices  $(0, 0)$ ,  $(2, 1)$ ,  $(0, 3)$ ;  $\rho(x, y) = x + y$
  - $D$  is the triangular region enclosed by the lines  $x = 0$ ,  $y = x$ , and  $2x + y = 6$ ;  $\rho(x, y) = x^2$
  - $D$  is bounded by  $y = 1 - x^2$  and  $y = 0$ ;  $\rho(x, y) = ky$
  - $D$  is bounded by  $y = x^2$  and  $y = x + 2$ ;  $\rho(x, y) = kx$
  - $D = \{(x, y) \mid 0 \leq y \leq \sin(\pi x/L), 0 \leq x \leq L\}$ ;  $\rho(x, y) = y$
  - $D$  is bounded by the parabolas  $y = x^2$  and  $x = y^2$ ;  $\rho(x, y) = \sqrt{x}$
- A lamina occupies the part of the disk  $x^2 + y^2 \leq 1$  in the first quadrant. Find its center of mass if the density at any point is proportional to its distance from the  $x$ -axis.
- Find the center of mass of the lamina in Exercise 11 if the density at any point is proportional to the square of its distance from the origin.
- The boundary of a lamina consists of the semicircles  $y = \sqrt{1 - x^2}$  and  $y = \sqrt{4 - x^2}$  together with the portions of the  $x$ -axis that join them. Find the center of mass of the lamina if the density at any point is proportional to its distance from the origin.
- Find the center of mass of the lamina in Exercise 13 if the density at any point is inversely proportional to its distance from the origin.
- Find the center of mass of a lamina in the shape of an isosceles right triangle with equal sides of length  $a$  if the density at any point is proportional to the square of the distance from the vertex opposite the hypotenuse.
- A lamina occupies the region inside the circle  $x^2 + y^2 = 2y$  but outside the circle  $x^2 + y^2 = 1$ . Find the center of mass if the density at any point is inversely proportional to its distance from the origin.
- Find the moments of inertia  $I_x, I_y, I_0$  for the lamina of Exercise 7.
- Find the moments of inertia  $I_x, I_y, I_0$  for the lamina of Exercise 12.
- Find the moments of inertia  $I_x, I_y, I_0$  for the lamina of Exercise 15.
- Consider a square fan blade with sides of length 2 and the lower left corner placed at the origin. If the density of the blade is  $\rho(x, y) = 1 + 0.1x$ , is it more difficult to rotate the blade about the  $x$ -axis or the  $y$ -axis?
- 24 A lamina with constant density  $\rho(x, y) = \rho$  occupies the given region. Find the moments of inertia  $I_x$  and  $I_y$  and the radii of gyration  $\bar{x}$  and  $\bar{y}$ .
  - The rectangle  $0 \leq x \leq b, 0 \leq y \leq h$
  - The triangle with vertices  $(0, 0)$ ,  $(b, 0)$ , and  $(0, h)$



23. The part of the disk  $x^2 + y^2 \leq a^2$  in the first quadrant  
 24. The region under the curve  $y = \sin x$  from  $x = 0$  to  $x = \pi$

**CAS** 25–26 Use a computer algebra system to find the mass, center of mass, and moments of inertia of the lamina that occupies the region  $D$  and has the given density function.

25.  $D$  is enclosed by the right loop of the four-leaved rose  
 $r = \cos 2\theta$ ;  $\rho(x, y) = x^2 + y^2$   
 26.  $D = \{(x, y) \mid 0 \leq y \leq xe^{-x}, 0 \leq x \leq 2\}$ ;  $\rho(x, y) = x^2y^2$

27. The joint density function for a pair of random variables  $X$  and  $Y$  is

$$f(x, y) = \begin{cases} Cx(1 + y) & \text{if } 0 \leq x \leq 1, 0 \leq y \leq 2 \\ 0 & \text{otherwise} \end{cases}$$

- (a) Find the value of the constant  $C$ .  
 (b) Find  $P(X \leq 1, Y \leq 1)$ .  
 (c) Find  $P(X + Y \leq 1)$ .  
 28. (a) Verify that

$$f(x, y) = \begin{cases} 4xy & \text{if } 0 \leq x \leq 1, 0 \leq y \leq 1 \\ 0 & \text{otherwise} \end{cases}$$

is a joint density function.

- (b) If  $X$  and  $Y$  are random variables whose joint density function is the function  $f$  in part (a), find  
 (i)  $P(X \geq \frac{1}{2})$       (ii)  $P(X \geq \frac{1}{2}, Y \leq \frac{1}{2})$   
 (c) Find the expected values of  $X$  and  $Y$ .  
 29. Suppose  $X$  and  $Y$  are random variables with joint density function

$$f(x, y) = \begin{cases} 0.1e^{-(0.5x+0.2y)} & \text{if } x \geq 0, y \geq 0 \\ 0 & \text{otherwise} \end{cases}$$

- (a) Verify that  $f$  is indeed a joint density function.  
 (b) Find the following probabilities.  
 (i)  $P(Y \geq 1)$       (ii)  $P(X \leq 2, Y \leq 4)$   
 (c) Find the expected values of  $X$  and  $Y$ .  
 30. (a) A lamp has two bulbs of a type with an average lifetime of 1000 hours. Assuming that we can model the probability of failure of these bulbs by an exponential density function with mean  $\mu = 1000$ , find the probability that both of the lamp's bulbs fail within 1000 hours.

- (b) Another lamp has just one bulb of the same type as in part (a). If one bulb burns out and is replaced by a bulb of the same type, find the probability that the two bulbs fail within a total of 1000 hours.

**CAS** 31. Suppose that  $X$  and  $Y$  are independent random variables, where  $X$  is normally distributed with mean 45 and standard deviation 0.5 and  $Y$  is normally distributed with mean 20 and standard deviation 0.1.

- (a) Find  $P(40 \leq X \leq 50, 20 \leq Y \leq 25)$ .  
 (b) Find  $P(4(X - 45)^2 + 100(Y - 20)^2 \leq 2)$ .

32. Xavier and Yolanda both have classes that end at noon and they agree to meet every day after class. They arrive at the coffee shop independently. Xavier's arrival time is  $X$  and Yolanda's arrival time is  $Y$ , where  $X$  and  $Y$  are measured in minutes after noon. The individual density functions are

$$f_1(x) = \begin{cases} e^{-x} & \text{if } x \geq 0 \\ 0 & \text{if } x < 0 \end{cases} \quad f_2(y) = \begin{cases} \frac{1}{50}y & \text{if } 0 \leq y \leq 10 \\ 0 & \text{otherwise} \end{cases}$$

(Xavier arrives sometime after noon and is more likely to arrive promptly than late. Yolanda always arrives by 12:10 PM and is more likely to arrive late than promptly.) After Yolanda arrives, she'll wait for up to half an hour for Xavier, but he won't wait for her. Find the probability that they meet.

33. When studying the spread of an epidemic, we assume that the probability that an infected individual will spread the disease to an uninfected individual is a function of the distance between them. Consider a circular city of radius 10 miles in which the population is uniformly distributed. For an uninfected individual at a fixed point  $A(x_0, y_0)$ , assume that the probability function is given by

$$f(P) = \frac{1}{20}[20 - d(P, A)]$$

where  $d(P, A)$  denotes the distance between points  $P$  and  $A$ .

- (a) Suppose the exposure of a person to the disease is the sum of the probabilities of catching the disease from all members of the population. Assume that the infected people are uniformly distributed throughout the city, with  $k$  infected individuals per square mile. Find a double integral that represents the exposure of a person residing at  $A$ .  
 (b) Evaluate the integral for the case in which  $A$  is the center of the city and for the case in which  $A$  is located on the edge of the city. Where would you prefer to live?

## 15.6 Surface Area

In Section 16.6 we will deal with areas of more general surfaces, called parametric surfaces, and so this section need not be covered if that later section will be covered.

In this section we apply double integrals to the problem of computing the area of a surface. In Section 8.2 we found the area of a very special type of surface—a surface of revolution—by the methods of single-variable calculus. Here we compute the area of a surface with equation  $z = f(x, y)$ , the graph of a function of two variables.

Let  $S$  be a surface with equation  $z = f(x, y)$ , where  $f$  has continuous partial derivatives. For simplicity in deriving the surface area formula, we assume that  $f(x, y) \geq 0$  and the

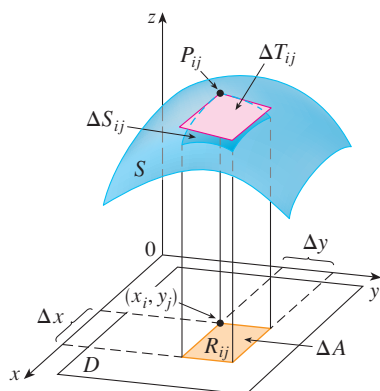


FIGURE 1

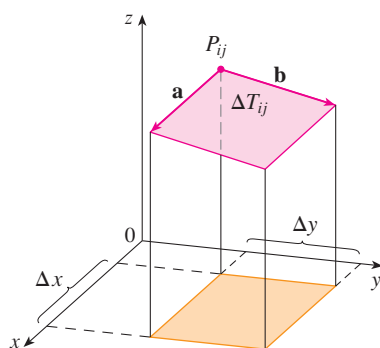


FIGURE 2

domain  $D$  of  $f$  is a rectangle. We divide  $D$  into small rectangles  $R_{ij}$  with area  $\Delta A = \Delta x \Delta y$ . If  $(x_i, y_j)$  is the corner of  $R_{ij}$  closest to the origin, let  $P_{ij}(x_i, y_j, f(x_i, y_j))$  be the point on  $S$  directly above it (see Figure 1). The tangent plane to  $S$  at  $P_{ij}$  is an approximation to  $S$  near  $P_{ij}$ . So the area  $\Delta T_{ij}$  of the part of this tangent plane (a parallelogram) that lies directly above  $R_{ij}$  is an approximation to the area  $\Delta S_{ij}$  of the part of  $S$  that lies directly above  $R_{ij}$ . Thus the sum  $\sum \sum \Delta T_{ij}$  is an approximation to the total area of  $S$ , and this approximation appears to improve as the number of rectangles increases. Therefore we define the **surface area** of  $S$  to be

1

$$A(S) = \lim_{m, n \rightarrow \infty} \sum_{i=1}^m \sum_{j=1}^n \Delta T_{ij}$$

To find a formula that is more convenient than Equation 1 for computational purposes, we let  $\mathbf{a}$  and  $\mathbf{b}$  be the vectors that start at  $P_{ij}$  and lie along the sides of the parallelogram with area  $\Delta T_{ij}$ . (See Figure 2.) Then  $\Delta T_{ij} = |\mathbf{a} \times \mathbf{b}|$ . Recall from Section 14.3 that  $f_x(x_i, y_j)$  and  $f_y(x_i, y_j)$  are the slopes of the tangent lines through  $P_{ij}$  in the directions of  $\mathbf{a}$  and  $\mathbf{b}$ . Therefore

$$\mathbf{a} = \Delta x \mathbf{i} + f_x(x_i, y_j) \Delta x \mathbf{k}$$

$$\mathbf{b} = \Delta y \mathbf{j} + f_y(x_i, y_j) \Delta y \mathbf{k}$$

and

$$\begin{aligned} \mathbf{a} \times \mathbf{b} &= \begin{vmatrix} \mathbf{i} & \mathbf{j} & \mathbf{k} \\ \Delta x & 0 & f_x(x_i, y_j) \Delta x \\ 0 & \Delta y & f_y(x_i, y_j) \Delta y \end{vmatrix} \\ &= -f_x(x_i, y_j) \Delta x \Delta y \mathbf{i} - f_y(x_i, y_j) \Delta x \Delta y \mathbf{j} + \Delta x \Delta y \mathbf{k} \\ &= [-f_x(x_i, y_j) \mathbf{i} - f_y(x_i, y_j) \mathbf{j} + \mathbf{k}] \Delta A \end{aligned}$$

$$\text{Thus} \quad \Delta T_{ij} = |\mathbf{a} \times \mathbf{b}| = \sqrt{[f_x(x_i, y_j)]^2 + [f_y(x_i, y_j)]^2 + 1} \Delta A$$

From Definition 1 we then have

$$\begin{aligned} A(S) &= \lim_{m, n \rightarrow \infty} \sum_{i=1}^m \sum_{j=1}^n \Delta T_{ij} \\ &= \lim_{m, n \rightarrow \infty} \sum_{i=1}^m \sum_{j=1}^n \sqrt{[f_x(x_i, y_j)]^2 + [f_y(x_i, y_j)]^2 + 1} \Delta A \end{aligned}$$

and by the definition of a double integral we get the following formula.

2

The area of the surface with equation  $z = f(x, y)$ ,  $(x, y) \in D$ , where  $f_x$  and  $f_y$  are continuous, is

$$A(S) = \iint_D \sqrt{[f_x(x, y)]^2 + [f_y(x, y)]^2 + 1} \, dA$$

We will verify in Section 16.6 that this formula is consistent with our previous formula for the area of a surface of revolution. If we use the alternative notation for partial derivatives, we can rewrite Formula 2 as follows:

$$\boxed{3} \quad A(s) = \iint_D \sqrt{1 + \left(\frac{\partial z}{\partial x}\right)^2 + \left(\frac{\partial z}{\partial y}\right)^2} dA$$

Notice the similarity between the surface area formula in Equation 3 and the arc length formula from Section 8.1:

$$L = \int_a^b \sqrt{1 + \left(\frac{dy}{dx}\right)^2} dx$$

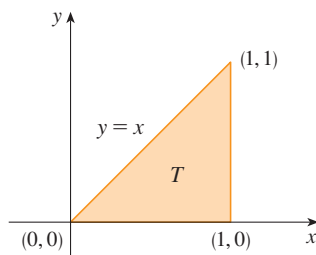


FIGURE 3

**EXAMPLE 1** Find the surface area of the part of the surface  $z = x^2 + 2y$  that lies above the triangular region  $T$  in the  $xy$ -plane with vertices  $(0, 0)$ ,  $(1, 0)$ , and  $(1, 1)$ .

**SOLUTION** The region  $T$  is shown in Figure 3 and is described by

$$T = \{(x, y) \mid 0 \leq x \leq 1, 0 \leq y \leq x\}$$

Using Formula 2 with  $f(x, y) = x^2 + 2y$ , we get

$$\begin{aligned} A &= \iint_T \sqrt{(2x)^2 + (2)^2 + 1} dA = \int_0^1 \int_0^x \sqrt{4x^2 + 5} dy dx \\ &= \int_0^1 x \sqrt{4x^2 + 5} dx = \frac{1}{8} \cdot \frac{2}{3} (4x^2 + 5)^{3/2} \Big|_0^1 = \frac{1}{12} (27 - 5\sqrt{5}) \end{aligned}$$

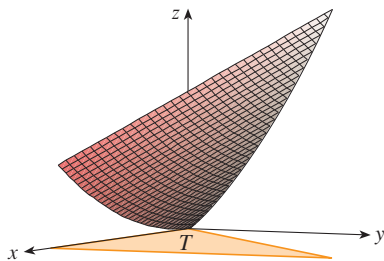


FIGURE 4

Figure 4 shows the portion of the surface whose area we have just computed.

**EXAMPLE 2** Find the area of the part of the paraboloid  $z = x^2 + y^2$  that lies under the plane  $z = 9$ .

**SOLUTION** The plane intersects the paraboloid in the circle  $x^2 + y^2 = 9$ ,  $z = 9$ . Therefore the given surface lies above the disk  $D$  with center the origin and radius 3. (See Figure 5.) Using Formula 3, we have

$$\begin{aligned} A &= \iint_D \sqrt{1 + \left(\frac{\partial z}{\partial x}\right)^2 + \left(\frac{\partial z}{\partial y}\right)^2} dA = \iint_D \sqrt{1 + (2x)^2 + (2y)^2} dA \\ &= \iint_D \sqrt{1 + 4(x^2 + y^2)} dA \end{aligned}$$

Converting to polar coordinates, we obtain

$$\begin{aligned} A &= \int_0^{2\pi} \int_0^3 \sqrt{1 + 4r^2} r dr d\theta = \int_0^{2\pi} d\theta \int_0^3 \frac{1}{8} \sqrt{1 + 4r^2} (8r) dr \\ &= 2\pi \left(\frac{1}{8}\right) \frac{2}{3} (1 + 4r^2)^{3/2} \Big|_0^3 = \frac{\pi}{6} (37\sqrt{37} - 1) \end{aligned}$$

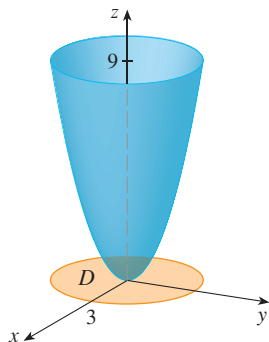


FIGURE 5

## 15.6 Exercises

1–12 Find the area of the surface.

1. The part of the plane  $z = 2 + 3x + 4y$  that lies above the rectangle  $[0, 5] \times [1, 4]$
2. The part of the plane  $2x + 5y + z = 10$  that lies inside the cylinder  $x^2 + y^2 = 9$
3. The part of the plane  $3x + 2y + z = 6$  that lies in the first octant
4. The part of the surface  $z = 1 + 3x + 2y^2$  that lies above the triangle with vertices  $(0, 0)$ ,  $(0, 1)$ , and  $(2, 1)$
5. The part of the cylinder  $y^2 + z^2 = 9$  that lies above the rectangle with vertices  $(0, 0)$ ,  $(4, 0)$ ,  $(0, 2)$ , and  $(4, 2)$
6. The part of the paraboloid  $z = 4 - x^2 - y^2$  that lies above the  $xy$ -plane
7. The part of the hyperbolic paraboloid  $z = y^2 - x^2$  that lies between the cylinders  $x^2 + y^2 = 1$  and  $x^2 + y^2 = 4$
8. The surface  $z = \frac{2}{3}(x^{3/2} + y^{3/2})$ ,  $0 \leq x \leq 1$ ,  $0 \leq y \leq 1$
9. The part of the surface  $z = xy$  that lies within the cylinder  $x^2 + y^2 = 1$
10. The part of the sphere  $x^2 + y^2 + z^2 = 4$  that lies above the plane  $z = 1$
11. The part of the sphere  $x^2 + y^2 + z^2 = a^2$  that lies within the cylinder  $x^2 + y^2 = ax$  and above the  $xy$ -plane
12. The part of the sphere  $x^2 + y^2 + z^2 = 4z$  that lies inside the paraboloid  $z = x^2 + y^2$

13–14 Find the area of the surface correct to four decimal places by expressing the area in terms of a single integral and using your calculator to estimate the integral.

13. The part of the surface  $z = e^{-x^2-y^2}$  that lies above the disk  $x^2 + y^2 \leq 4$
14. The part of the surface  $z = \cos(x^2 + y^2)$  that lies inside the cylinder  $x^2 + y^2 = 1$

15. (a) Use the Midpoint Rule for double integrals (see Section 15.1) with four squares to estimate the surface area of the portion of the paraboloid  $z = x^2 + y^2$  that lies above the square  $[0, 1] \times [0, 1]$ .

CAS

- (b) Use a computer algebra system to approximate the surface area in part (a) to four decimal places. Compare with the answer to part (a).

16. (a) Use the Midpoint Rule for double integrals with  $m = n = 2$  to estimate the area of the surface  $z = xy + x^2 + y^2$ ,  $0 \leq x \leq 2$ ,  $0 \leq y \leq 2$ .

CAS

- (b) Use a computer algebra system to approximate the surface area in part (a) to four decimal places. Compare with the answer to part (a).

CAS

17. Find the exact area of the surface  $z = 1 + 2x + 3y + 4y^2$ ,  $1 \leq x \leq 4$ ,  $0 \leq y \leq 1$ .

CAS

18. Find the exact area of the surface

$$z = 1 + x + y + x^2 \quad -2 \leq x \leq 1 \quad -1 \leq y \leq 1$$

Illustrate by graphing the surface.

CAS

19. Find, to four decimal places, the area of the part of the surface  $z = 1 + x^2y^2$  that lies above the disk  $x^2 + y^2 \leq 1$ .

CAS

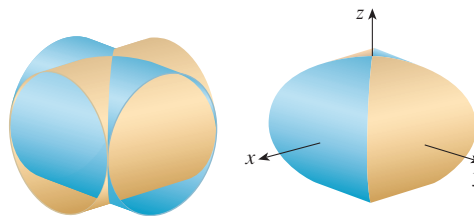
20. Find, to four decimal places, the area of the part of the surface  $z = (1 + x^2)/(1 + y^2)$  that lies above the square  $|x| + |y| \leq 1$ . Illustrate by graphing this part of the surface.

21. Show that the area of the part of the plane  $z = ax + by + c$  that projects onto a region  $D$  in the  $xy$ -plane with area  $A(D)$  is  $\sqrt{a^2 + b^2 + 1}A(D)$ .

22. If you attempt to use Formula 2 to find the area of the top half of the sphere  $x^2 + y^2 + z^2 = a^2$ , you have a slight problem because the double integral is improper. In fact, the integrand has an infinite discontinuity at every point of the boundary circle  $x^2 + y^2 = a^2$ . However, the integral can be computed as the limit of the integral over the disk  $x^2 + y^2 \leq t^2$  as  $t \rightarrow a^-$ . Use this method to show that the area of a sphere of radius  $a$  is  $4\pi a^2$ .

23. Find the area of the finite part of the paraboloid  $y = x^2 + z^2$  cut off by the plane  $y = 25$ . [Hint: Project the surface onto the  $xz$ -plane.]

24. The figure shows the surface created when the cylinder  $y^2 + z^2 = 1$  intersects the cylinder  $x^2 + z^2 = 1$ . Find the area of this surface.



## 15.7 Triple Integrals

Just as we defined single integrals for functions of one variable and double integrals for functions of two variables, so we can define triple integrals for functions of three variables. Let's first deal with the simplest case where  $f$  is defined on a rectangular box:

$$\mathbf{1} \quad B = \{(x, y, z) \mid a \leq x \leq b, c \leq y \leq d, r \leq z \leq s\}$$

The first step is to divide  $B$  into sub-boxes. We do this by dividing the interval  $[a, b]$  into  $l$  subintervals  $[x_{i-1}, x_i]$  of equal width  $\Delta x$ , dividing  $[c, d]$  into  $m$  subintervals of width  $\Delta y$ , and dividing  $[r, s]$  into  $n$  subintervals of width  $\Delta z$ . The planes through the endpoints of these subintervals parallel to the coordinate planes divide the box  $B$  into  $lmn$  sub-boxes

$$B_{ijk} = [x_{i-1}, x_i] \times [y_{j-1}, y_j] \times [z_{k-1}, z_k]$$

which are shown in Figure 1. Each sub-box has volume  $\Delta V = \Delta x \Delta y \Delta z$ .

Then we form the **triple Riemann sum**

$$\mathbf{2} \quad \sum_{i=1}^l \sum_{j=1}^m \sum_{k=1}^n f(x_{ijk}^*, y_{ijk}^*, z_{ijk}^*) \Delta V$$

where the sample point  $(x_{ijk}^*, y_{ijk}^*, z_{ijk}^*)$  is in  $B_{ijk}$ . By analogy with the definition of a double integral (15.1.5), we define the triple integral as the limit of the triple Riemann sums in [2].

**3 Definition** The **triple integral** of  $f$  over the box  $B$  is

$$\iiint_B f(x, y, z) \, dV = \lim_{l, m, n \rightarrow \infty} \sum_{i=1}^l \sum_{j=1}^m \sum_{k=1}^n f(x_{ijk}^*, y_{ijk}^*, z_{ijk}^*) \Delta V$$

if this limit exists.

Again, the triple integral always exists if  $f$  is continuous. We can choose the sample point to be any point in the sub-box, but if we choose it to be the point  $(x_i, y_j, z_k)$  we get a simpler-looking expression for the triple integral:

$$\iiint_B f(x, y, z) \, dV = \lim_{l, m, n \rightarrow \infty} \sum_{i=1}^l \sum_{j=1}^m \sum_{k=1}^n f(x_i, y_j, z_k) \Delta V$$

Just as for double integrals, the practical method for evaluating triple integrals is to express them as iterated integrals as follows.

**4 Fubini's Theorem for Triple Integrals** If  $f$  is continuous on the rectangular box  $B = [a, b] \times [c, d] \times [r, s]$ , then

$$\iiint_B f(x, y, z) \, dV = \int_r^s \int_c^d \int_a^b f(x, y, z) \, dx \, dy \, dz$$

The iterated integral on the right side of Fubini's Theorem means that we integrate first with respect to  $x$  (keeping  $y$  and  $z$  fixed), then we integrate with respect to  $y$  (keeping  $z$  fixed), and finally we integrate with respect to  $z$ . There are five other possible orders in

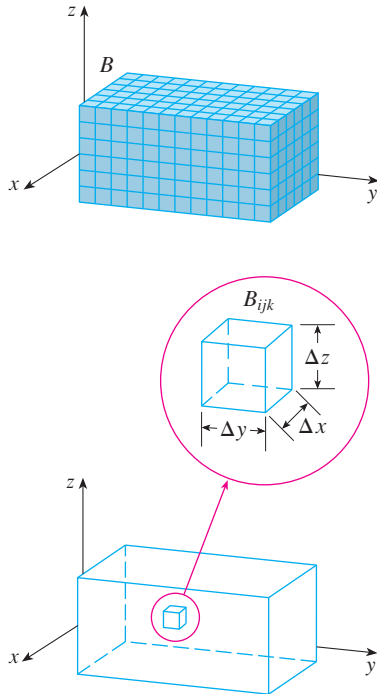


FIGURE 1

which we can integrate, all of which give the same value. For instance, if we integrate with respect to  $y$ , then  $z$ , and then  $x$ , we have

$$\iiint_B f(x, y, z) dV = \int_a^b \int_r^s \int_c^d f(x, y, z) dy dz dx$$

**V EXAMPLE 1** Evaluate the triple integral  $\iiint_B xyz^2 dV$ , where  $B$  is the rectangular box given by

$$B = \{(x, y, z) \mid 0 \leq x \leq 1, -1 \leq y \leq 2, 0 \leq z \leq 3\}$$

**SOLUTION** We could use any of the six possible orders of integration. If we choose to integrate with respect to  $x$ , then  $y$ , and then  $z$ , we obtain

$$\begin{aligned} \iiint_B xyz^2 dV &= \int_0^3 \int_{-1}^2 \int_0^1 xyz^2 dx dy dz = \int_0^3 \int_{-1}^2 \left[ \frac{x^2 yz^2}{2} \right]_{x=0}^{x=1} dy dz \\ &= \int_0^3 \int_{-1}^2 \frac{yz^2}{2} dy dz = \int_0^3 \left[ \frac{y^2 z^2}{4} \right]_{y=-1}^{y=2} dz \\ &= \int_0^3 \frac{3z^2}{4} dz = \left. \frac{z^3}{4} \right|_0^3 = \frac{27}{4} \end{aligned}$$

Now we define the **triple integral over a general bounded region  $E$**  in three-dimensional space (a solid) by much the same procedure that we used for double integrals (15.3.2). We enclose  $E$  in a box  $B$  of the type given by Equation 1. Then we define  $F$  so that it agrees with  $f$  on  $E$  but is 0 for points in  $B$  that are outside  $E$ . By definition,

$$\iiint_E f(x, y, z) dV = \iiint_B F(x, y, z) dV$$

This integral exists if  $f$  is continuous and the boundary of  $E$  is “reasonably smooth.” The triple integral has essentially the same properties as the double integral (Properties 6–9 in Section 15.3).

We restrict our attention to continuous functions  $f$  and to certain simple types of regions. A solid region  $E$  is said to be of **type 1** if it lies between the graphs of two continuous functions of  $x$  and  $y$ , that is,

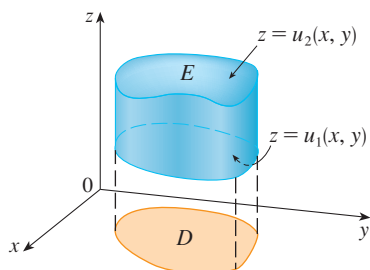
$$\boxed{5} \quad E = \{(x, y, z) \mid (x, y) \in D, u_1(x, y) \leq z \leq u_2(x, y)\}$$

where  $D$  is the projection of  $E$  onto the  $xy$ -plane as shown in Figure 2. Notice that the upper boundary of the solid  $E$  is the surface with equation  $z = u_2(x, y)$ , while the lower boundary is the surface  $z = u_1(x, y)$ .

By the same sort of argument that led to (15.3.3), it can be shown that if  $E$  is a type 1 region given by Equation 5, then

$$\boxed{6} \quad \iiint_E f(x, y, z) dV = \iint_D \left[ \int_{u_1(x, y)}^{u_2(x, y)} f(x, y, z) dz \right] dA$$

The meaning of the inner integral on the right side of Equation 6 is that  $x$  and  $y$  are held fixed, and therefore  $u_1(x, y)$  and  $u_2(x, y)$  are regarded as constants, while  $f(x, y, z)$  is integrated with respect to  $z$ .



**FIGURE 2**  
A type 1 solid region

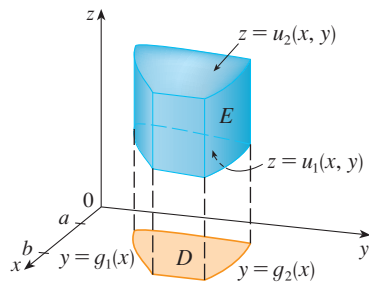


FIGURE 3

A type 1 solid region where the projection  $D$  is a type I plane region

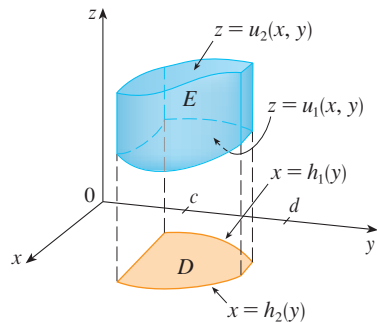


FIGURE 4

A type 1 solid region with a type II projection

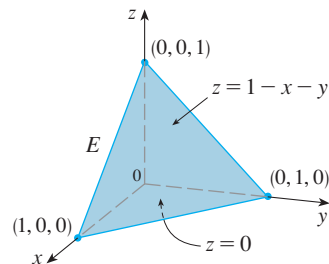


FIGURE 5

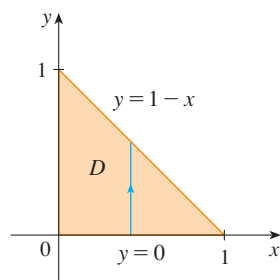


FIGURE 6

In particular, if the projection  $D$  of  $E$  onto the  $xy$ -plane is a type I plane region (as in Figure 3), then

$$E = \{(x, y, z) \mid a \leq x \leq b, g_1(x) \leq y \leq g_2(x), u_1(x, y) \leq z \leq u_2(x, y)\}$$

and Equation 6 becomes

$$\iiint_E f(x, y, z) \, dV = \int_a^b \int_{g_1(x)}^{g_2(x)} \int_{u_1(x, y)}^{u_2(x, y)} f(x, y, z) \, dz \, dy \, dx$$

If, on the other hand,  $D$  is a type II plane region (as in Figure 4), then

$$E = \{(x, y, z) \mid c \leq y \leq d, h_1(y) \leq x \leq h_2(y), u_1(x, y) \leq z \leq u_2(x, y)\}$$

and Equation 6 becomes

$$\iiint_E f(x, y, z) \, dV = \int_c^d \int_{h_1(y)}^{h_2(y)} \int_{u_1(x, y)}^{u_2(x, y)} f(x, y, z) \, dz \, dx \, dy$$

**EXAMPLE 2** Evaluate  $\iiint_E z \, dV$ , where  $E$  is the solid tetrahedron bounded by the four planes  $x = 0$ ,  $y = 0$ ,  $z = 0$ , and  $x + y + z = 1$ .

**SOLUTION** When we set up a triple integral it's wise to draw *two* diagrams: one of the solid region  $E$  (see Figure 5) and one of its projection  $D$  onto the  $xy$ -plane (see Figure 6). The lower boundary of the tetrahedron is the plane  $z = 0$  and the upper boundary is the plane  $x + y + z = 1$  (or  $z = 1 - x - y$ ), so we use  $u_1(x, y) = 0$  and  $u_2(x, y) = 1 - x - y$  in Formula 7. Notice that the planes  $x + y + z = 1$  and  $z = 0$  intersect in the line  $x + y = 1$  (or  $y = 1 - x$ ) in the  $xy$ -plane. So the projection of  $E$  is the triangular region shown in Figure 6, and we have

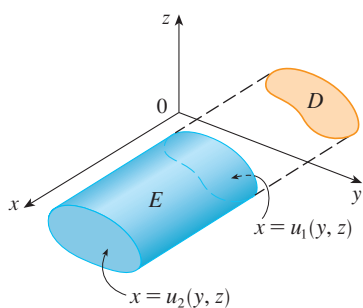
$$E = \{(x, y, z) \mid 0 \leq x \leq 1, 0 \leq y \leq 1 - x, 0 \leq z \leq 1 - x - y\}$$

This description of  $E$  as a type 1 region enables us to evaluate the integral as follows:

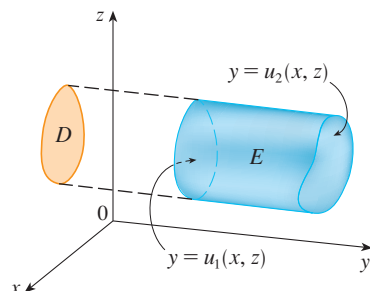
$$\begin{aligned} \iiint_E z \, dV &= \int_0^1 \int_0^{1-x} \int_0^{1-x-y} z \, dz \, dy \, dx = \int_0^1 \int_0^{1-x} \left[ \frac{z^2}{2} \right]_{z=0}^{z=1-x-y} dy \, dx \\ &= \frac{1}{2} \int_0^1 \int_0^{1-x} (1-x-y)^2 dy \, dx = \frac{1}{2} \int_0^1 \left[ -\frac{(1-x-y)^3}{3} \right]_{y=0}^{y=1-x} dx \\ &= \frac{1}{6} \int_0^1 (1-x)^3 dx = \frac{1}{6} \left[ -\frac{(1-x)^4}{4} \right]_0^1 = \frac{1}{24} \end{aligned}$$

A solid region  $E$  is of **type 2** if it is of the form

$$E = \{(x, y, z) \mid (y, z) \in D, u_1(y, z) \leq x \leq u_2(y, z)\}$$



**FIGURE 7**  
A type 2 region



**FIGURE 8**  
A type 3 region

where, this time,  $D$  is the projection of  $E$  onto the  $yz$ -plane (see Figure 7). The back surface is  $x = u_1(y, z)$ , the front surface is  $x = u_2(y, z)$ , and we have

$$\boxed{10} \quad \iiint_E f(x, y, z) \, dV = \iint_D \left[ \int_{u_1(y, z)}^{u_2(y, z)} f(x, y, z) \, dx \right] dA$$

Finally, a **type 3** region is of the form

$$E = \{(x, y, z) \mid (x, z) \in D, u_1(x, z) \leq y \leq u_2(x, z)\}$$

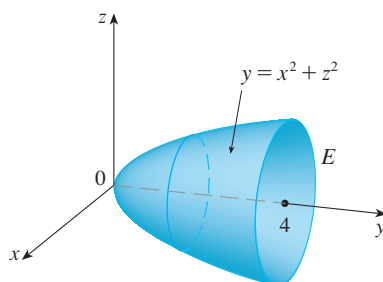
where  $D$  is the projection of  $E$  onto the  $xz$ -plane,  $y = u_1(x, z)$  is the left surface, and  $y = u_2(x, z)$  is the right surface (see Figure 8). For this type of region we have

$$\boxed{11} \quad \iiint_E f(x, y, z) \, dV = \iint_D \left[ \int_{u_1(x, z)}^{u_2(x, z)} f(x, y, z) \, dy \right] dA$$

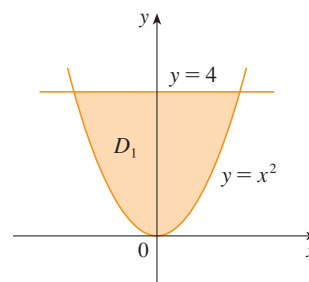
In each of Equations 10 and 11 there may be two possible expressions for the integral depending on whether  $D$  is a type I or type II plane region (and corresponding to Equations 7 and 8).

**V EXAMPLE 3** Evaluate  $\iiint_E \sqrt{x^2 + z^2} \, dV$ , where  $E$  is the region bounded by the paraboloid  $y = x^2 + z^2$  and the plane  $y = 4$ .

**SOLUTION** The solid  $E$  is shown in Figure 9. If we regard it as a type 1 region, then we need to consider its projection  $D_1$  onto the  $xy$ -plane, which is the parabolic region in Figure 10. (The trace of  $y = x^2 + z^2$  in the plane  $z = 0$  is the parabola  $y = x^2$ .)



**FIGURE 9**  
Region of integration



**FIGURE 10**  
Projection onto  $xy$ -plane

**TEC** Visual 15.7 illustrates how solid regions (including the one in Figure 9) project onto coordinate planes.

From  $y = x^2 + z^2$  we obtain  $z = \pm\sqrt{y - x^2}$ , so the lower boundary surface of  $E$  is  $z = -\sqrt{y - x^2}$  and the upper surface is  $z = \sqrt{y - x^2}$ . Therefore the description of  $E$  as a type 1 region is

$$E = \{(x, y, z) \mid -2 \leq x \leq 2, x^2 \leq y \leq 4, -\sqrt{y - x^2} \leq z \leq \sqrt{y - x^2}\}$$

and so we obtain

$$\iiint_E \sqrt{x^2 + z^2} \, dV = \int_{-2}^2 \int_{x^2}^4 \int_{-\sqrt{y-x^2}}^{\sqrt{y-x^2}} \sqrt{x^2 + z^2} \, dz \, dy \, dx$$



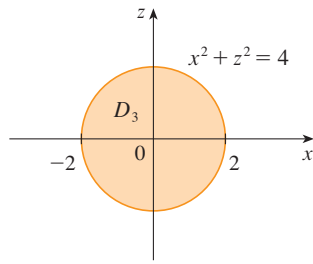



FIGURE 11

Projection onto  $xz$ -plane

 The most difficult step in evaluating a triple integral is setting up an expression for the region of integration (such as Equation 9 in Example 2). Remember that the limits of integration in the inner integral contain at most two variables, the limits of integration in the middle integral contain at most one variable, and the limits of integration in the outer integral must be constants.

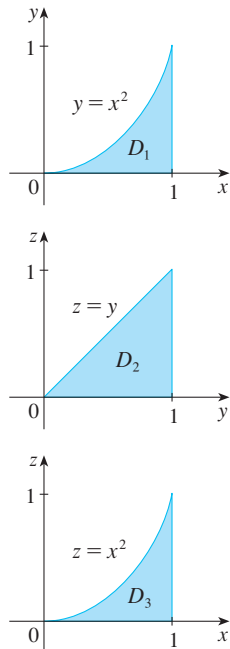


FIGURE 12

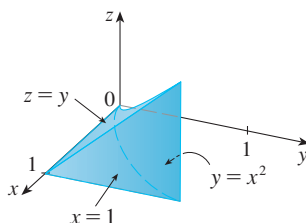
Projections of  $E$ 

FIGURE 13

The solid  $E$ 

Although this expression is correct, it is extremely difficult to evaluate. So let's instead consider  $E$  as a type 3 region. As such, its projection  $D_3$  onto the  $xz$ -plane is the disk  $x^2 + z^2 \leq 4$  shown in Figure 11.

Then the left boundary of  $E$  is the paraboloid  $y = x^2 + z^2$  and the right boundary is the plane  $y = 4$ , so taking  $u_1(x, z) = x^2 + z^2$  and  $u_2(x, z) = 4$  in Equation 11, we have

$$\iiint_E \sqrt{x^2 + z^2} \, dV = \iint_{D_3} \left[ \int_{x^2+z^2}^4 \sqrt{x^2 + z^2} \, dy \right] dA = \iint_{D_3} (4 - x^2 - z^2) \sqrt{x^2 + z^2} \, dA$$

Although this integral could be written as

$$\int_{-2}^2 \int_{-\sqrt{4-x^2}}^{\sqrt{4-x^2}} (4 - x^2 - z^2) \sqrt{x^2 + z^2} \, dz \, dx$$

it's easier to convert to polar coordinates in the  $xz$ -plane:  $x = r \cos \theta$ ,  $z = r \sin \theta$ . This gives

$$\begin{aligned} \iiint_E \sqrt{x^2 + z^2} \, dV &= \iint_{D_3} (4 - x^2 - z^2) \sqrt{x^2 + z^2} \, dA \\ &= \int_0^{2\pi} \int_0^2 (4 - r^2) r \, dr \, d\theta = \int_0^{2\pi} d\theta \int_0^2 (4r^2 - r^4) \, dr \\ &= 2\pi \left[ \frac{4r^3}{3} - \frac{r^5}{5} \right]_0^2 = \frac{128\pi}{15} \end{aligned}$$

**EXAMPLE 4** Express the iterated integral  $\int_0^1 \int_0^{x^2} \int_0^y f(x, y, z) \, dz \, dy \, dx$  as a triple integral and then rewrite it as an iterated integral in a different order, integrating first with respect to  $x$ , then  $z$ , and then  $y$ .

**SOLUTION** We can write

$$\int_0^1 \int_0^{x^2} \int_0^y f(x, y, z) \, dz \, dy \, dx = \iiint_E f(x, y, z) \, dV$$

where  $E = \{(x, y, z) \mid 0 \leq x \leq 1, 0 \leq y \leq x^2, 0 \leq z \leq y\}$ . This description of  $E$  enables us to write projections onto the three coordinate planes as follows:

$$\begin{aligned} \text{on the } xy\text{-plane:} \quad D_1 &= \{(x, y) \mid 0 \leq x \leq 1, 0 \leq y \leq x^2\} \\ &= \{(x, y) \mid 0 \leq y \leq 1, \sqrt{y} \leq x \leq 1\} \\ \text{on the } yz\text{-plane:} \quad D_2 &= \{(x, y) \mid 0 \leq y \leq 1, 0 \leq z \leq y\} \\ \text{on the } xz\text{-plane:} \quad D_3 &= \{(x, y) \mid 0 \leq x \leq 1, 0 \leq z \leq x^2\} \end{aligned}$$

From the resulting sketches of the projections in Figure 12 we sketch the solid  $E$  in Figure 13. We see that it is the solid enclosed by the planes  $z = 0$ ,  $x = 1$ ,  $y = z$  and the parabolic cylinder  $y = x^2$  (or  $x = \sqrt{y}$ ).

If we integrate first with respect to  $x$ , then  $z$ , and then  $y$ , we use an alternate description of  $E$ :

$$E = \{(x, y, z) \mid 0 \leq x \leq 1, 0 \leq z \leq y, \sqrt{y} \leq x \leq 1\}$$

Thus

$$\iiint_E f(x, y, z) \, dV = \int_0^1 \int_0^y \int_{\sqrt{y}}^1 f(x, y, z) \, dx \, dz \, dy$$

### Applications of Triple Integrals

Recall that if  $f(x) \geq 0$ , then the single integral  $\int_a^b f(x) dx$  represents the area under the curve  $y = f(x)$  from  $a$  to  $b$ , and if  $f(x, y) \geq 0$ , then the double integral  $\iint_D f(x, y) dA$  represents the volume under the surface  $z = f(x, y)$  and above  $D$ . The corresponding interpretation of a triple integral  $\iiint_E f(x, y, z) dV$ , where  $f(x, y, z) \geq 0$ , is not very useful because it would be the “hypervolume” of a four-dimensional object and, of course, that is very difficult to visualize. (Remember that  $E$  is just the domain of the function  $f$ ; the graph of  $f$  lies in four-dimensional space.) Nonetheless, the triple integral  $\iiint_E f(x, y, z) dV$  can be interpreted in different ways in different physical situations, depending on the physical interpretations of  $x$ ,  $y$ ,  $z$ , and  $f(x, y, z)$ .

Let’s begin with the special case where  $f(x, y, z) = 1$  for all points in  $E$ . Then the triple integral does represent the volume of  $E$ :

12

$$V(E) = \iiint_E dV$$

For example, you can see this in the case of a type 1 region by putting  $f(x, y, z) = 1$  in Formula 6:

$$\iiint_E 1 dV = \iint_D \left[ \int_{u_1(x, y)}^{u_2(x, y)} dz \right] dA = \iint_D [u_2(x, y) - u_1(x, y)] dA$$

and from Section 15.3 we know this represents the volume that lies between the surfaces  $z = u_1(x, y)$  and  $z = u_2(x, y)$ .

**EXAMPLE 5** Use a triple integral to find the volume of the tetrahedron  $T$  bounded by the planes  $x + 2y + z = 2$ ,  $x = 2y$ ,  $x = 0$ , and  $z = 0$ .

**SOLUTION** The tetrahedron  $T$  and its projection  $D$  onto the  $xy$ -plane are shown in Figures 14 and 15. The lower boundary of  $T$  is the plane  $z = 0$  and the upper boundary is the plane  $x + 2y + z = 2$ , that is,  $z = 2 - x - 2y$ .

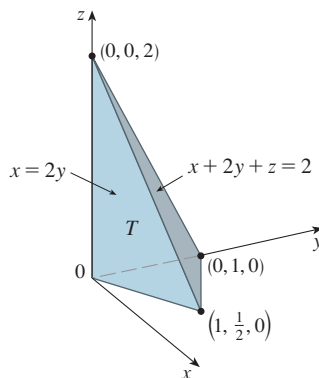


FIGURE 14

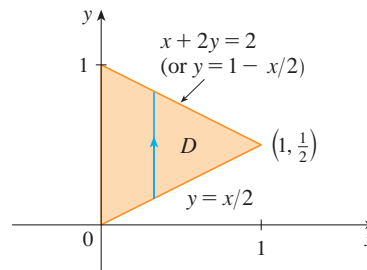


FIGURE 15

Therefore we have

$$\begin{aligned} V(T) &= \iiint_T dV = \int_0^1 \int_{x/2}^{1-x/2} \int_0^{2-x-2y} dz dy dx \\ &= \int_0^1 \int_{x/2}^{1-x/2} (2 - x - 2y) dy dx = \frac{1}{3} \end{aligned}$$

by the same calculation as in Example 4 in Section 15.3.

(Notice that it is not necessary to use triple integrals to compute volumes. They simply give an alternative method for setting up the calculation.)

All the applications of double integrals in Section 15.5 can be immediately extended to triple integrals. For example, if the density function of a solid object that occupies the region  $E$  is  $\rho(x, y, z)$ , in units of mass per unit volume, at any given point  $(x, y, z)$ , then its **mass** is

$$13 \quad m = \iiint_E \rho(x, y, z) \, dV$$

and its **moments** about the three coordinate planes are

$$14 \quad M_{yz} = \iiint_E x \rho(x, y, z) \, dV \quad M_{xz} = \iiint_E y \rho(x, y, z) \, dV$$

$$M_{xy} = \iiint_E z \rho(x, y, z) \, dV$$

The **center of mass** is located at the point  $(\bar{x}, \bar{y}, \bar{z})$ , where

$$15 \quad \bar{x} = \frac{M_{yz}}{m} \quad \bar{y} = \frac{M_{xz}}{m} \quad \bar{z} = \frac{M_{xy}}{m}$$

If the density is constant, the center of mass of the solid is called the **centroid** of  $E$ . The **moments of inertia** about the three coordinate axes are

$$16 \quad I_x = \iiint_E (y^2 + z^2) \rho(x, y, z) \, dV \quad I_y = \iiint_E (x^2 + z^2) \rho(x, y, z) \, dV$$

$$I_z = \iiint_E (x^2 + y^2) \rho(x, y, z) \, dV$$

As in Section 15.5, the total **electric charge** on a solid object occupying a region  $E$  and having charge density  $\sigma(x, y, z)$  is

$$Q = \iiint_E \sigma(x, y, z) \, dV$$

If we have three continuous random variables  $X$ ,  $Y$ , and  $Z$ , their **joint density function** is a function of three variables such that the probability that  $(X, Y, Z)$  lies in  $E$  is

$$P((X, Y, Z) \in E) = \iiint_E f(x, y, z) \, dV$$

In particular,

$$P(a \leq X \leq b, c \leq Y \leq d, r \leq Z \leq s) = \int_a^b \int_c^d \int_r^s f(x, y, z) \, dz \, dy \, dx$$

The joint density function satisfies

$$f(x, y, z) \geq 0 \quad \int_{-\infty}^{\infty} \int_{-\infty}^{\infty} \int_{-\infty}^{\infty} f(x, y, z) \, dz \, dy \, dx = 1$$

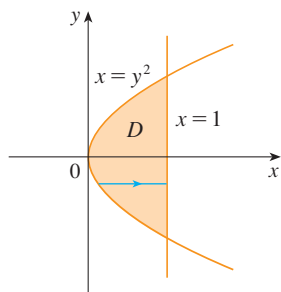
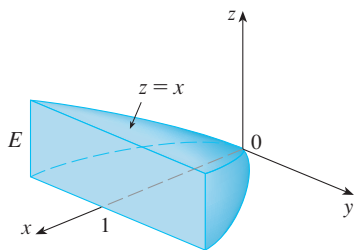


FIGURE 16

**V EXAMPLE 6** Find the center of mass of a solid of constant density that is bounded by the parabolic cylinder  $x = y^2$  and the planes  $x = z$ ,  $z = 0$ , and  $x = 1$ .

**SOLUTION** The solid  $E$  and its projection onto the  $xy$ -plane are shown in Figure 16. The lower and upper surfaces of  $E$  are the planes  $z = 0$  and  $z = x$ , so we describe  $E$  as a type I region:

$$E = \{(x, y, z) \mid -1 \leq y \leq 1, y^2 \leq x \leq 1, 0 \leq z \leq x\}$$

Then, if the density is  $\rho(x, y, z) = \rho$ , the mass is

$$\begin{aligned} m &= \iiint_E \rho \, dV = \int_{-1}^1 \int_{y^2}^1 \int_0^x \rho \, dz \, dx \, dy \\ &= \rho \int_{-1}^1 \int_{y^2}^1 x \, dx \, dy = \rho \int_{-1}^1 \left[ \frac{x^2}{2} \right]_{x=y^2}^{x=1} dy \\ &= \frac{\rho}{2} \int_{-1}^1 (1 - y^4) \, dy = \rho \int_0^1 (1 - y^4) \, dy \\ &= \rho \left[ y - \frac{y^5}{5} \right]_0^1 = \frac{4\rho}{5} \end{aligned}$$

Because of the symmetry of  $E$  and  $\rho$  about the  $xz$ -plane, we can immediately say that  $M_{xz} = 0$  and therefore  $\bar{y} = 0$ . The other moments are

$$\begin{aligned} M_{yz} &= \iiint_E x\rho \, dV = \int_{-1}^1 \int_{y^2}^1 \int_0^x x\rho \, dz \, dx \, dy \\ &= \rho \int_{-1}^1 \int_{y^2}^1 x^2 \, dx \, dy = \rho \int_{-1}^1 \left[ \frac{x^3}{3} \right]_{x=y^2}^{x=1} dy \\ &= \frac{2\rho}{3} \int_0^1 (1 - y^6) \, dy = \frac{2\rho}{3} \left[ y - \frac{y^7}{7} \right]_0^1 = \frac{4\rho}{7} \end{aligned}$$

$$\begin{aligned} M_{xy} &= \iiint_E z\rho \, dV = \int_{-1}^1 \int_{y^2}^1 \int_0^x z\rho \, dz \, dx \, dy \\ &= \rho \int_{-1}^1 \int_{y^2}^1 \left[ \frac{z^2}{2} \right]_{z=0}^{z=x} dx \, dy = \frac{\rho}{2} \int_{-1}^1 \int_{y^2}^1 x^2 \, dx \, dy \\ &= \frac{\rho}{3} \int_0^1 (1 - y^6) \, dy = \frac{2\rho}{7} \end{aligned}$$

Therefore the center of mass is

$$(\bar{x}, \bar{y}, \bar{z}) = \left( \frac{M_{yz}}{m}, \frac{M_{xz}}{m}, \frac{M_{xy}}{m} \right) = \left( \frac{5}{7}, 0, \frac{5}{14} \right)$$

## 15.7 Exercises

1. Evaluate the integral in Example 1, integrating first with respect to  $y$ , then  $z$ , and then  $x$ .

2. Evaluate the integral  $\iiint_E (xy + z^2) dV$ , where

$$E = \{(x, y, z) \mid 0 \leq x \leq 2, 0 \leq y \leq 1, 0 \leq z \leq 3\}$$

using three different orders of integration.

3–8 Evaluate the iterated integral.

3.  $\int_0^2 \int_0^{z^2} \int_0^{y-z} (2x - y) dx dy dz$     4.  $\int_0^1 \int_x^{2x} \int_0^y 2xyz dz dy dx$

5.  $\int_1^2 \int_0^{2z} \int_0^{\ln x} xe^{-y} dy dx dz$     6.  $\int_0^1 \int_0^1 \int_0^{\sqrt{1-z^2}} \frac{z}{y+1} dx dz dy$

7.  $\int_0^{\pi/2} \int_0^y \int_0^x \cos(x+y+z) dz dx dy$

8.  $\int_0^{\sqrt{\pi}} \int_0^x \int_0^{xz} x^2 \sin y dy dz dx$

9–18 Evaluate the triple integral.

9.  $\iiint_E y dV$ , where

$$E = \{(x, y, z) \mid 0 \leq x \leq 3, 0 \leq y \leq x, x - y \leq z \leq x + y\}$$

10.  $\iiint_E e^{z/y} dV$ , where

$$E = \{(x, y, z) \mid 0 \leq y \leq 1, y \leq x \leq 1, 0 \leq z \leq xy\}$$

11.  $\iiint_E \frac{z}{x^2 + z^2} dV$ , where

$$E = \{(x, y, z) \mid 1 \leq y \leq 4, y \leq z \leq 4, 0 \leq x \leq z\}$$

12.  $\iiint_E \sin y dV$ , where  $E$  lies below the plane  $z = x$  and above the triangular region with vertices  $(0, 0, 0)$ ,  $(\pi, 0, 0)$ , and  $(0, \pi, 0)$

13.  $\iiint_E 6xy dV$ , where  $E$  lies under the plane  $z = 1 + x + y$  and above the region in the  $xy$ -plane bounded by the curves  $y = \sqrt{x}$ ,  $y = 0$ , and  $x = 1$

14.  $\iiint_E xy dV$ , where  $E$  is bounded by the parabolic cylinders  $y = x^2$  and  $x = y^2$  and the planes  $z = 0$  and  $z = x + y$

15.  $\iiint_T x^2 dV$ , where  $T$  is the solid tetrahedron with vertices  $(0, 0, 0)$ ,  $(1, 0, 0)$ ,  $(0, 1, 0)$ , and  $(0, 0, 1)$

16.  $\iiint_T xyz dV$ , where  $T$  is the solid tetrahedron with vertices  $(0, 0, 0)$ ,  $(1, 0, 0)$ ,  $(1, 1, 0)$ , and  $(1, 0, 1)$

17.  $\iiint_E x dV$ , where  $E$  is bounded by the paraboloid  $x = 4y^2 + 4z^2$  and the plane  $x = 4$

18.  $\iiint_E z dV$ , where  $E$  is bounded by the cylinder  $y^2 + z^2 = 9$  and the planes  $x = 0$ ,  $y = 3x$ , and  $z = 0$  in the first octant

19–22 Use a triple integral to find the volume of the given solid.

19. The tetrahedron enclosed by the coordinate planes and the plane  $2x + y + z = 4$

20. The solid enclosed by the paraboloids  $y = x^2 + z^2$  and  $y = 8 - x^2 - z^2$

21. The solid enclosed by the cylinder  $y = x^2$  and the planes  $z = 0$  and  $y + z = 1$

22. The solid enclosed by the cylinder  $x^2 + z^2 = 4$  and the planes  $y = -1$  and  $y + z = 4$

23. (a) Express the volume of the wedge in the first octant that is cut from the cylinder  $y^2 + z^2 = 1$  by the planes  $y = x$  and  $x = 1$  as a triple integral.

CAS

(b) Use either the Table of Integrals (on Reference Pages 6–10) or a computer algebra system to find the exact value of the triple integral in part (a).

24. (a) In the **Midpoint Rule for triple integrals** we use a triple Riemann sum to approximate a triple integral over a box  $B$ , where  $f(x, y, z)$  is evaluated at the center  $(\bar{x}_i, \bar{y}_j, \bar{z}_k)$  of the box  $B_{ijk}$ . Use the Midpoint Rule to estimate  $\iiint_B \sqrt{x^2 + y^2 + z^2} dV$ , where  $B$  is the cube defined by  $0 \leq x \leq 4$ ,  $0 \leq y \leq 4$ ,  $0 \leq z \leq 4$ . Divide  $B$  into eight cubes of equal size.

CAS

(b) Use a computer algebra system to approximate the integral in part (a) correct to the nearest integer. Compare with the answer to part (a).

25–26 Use the Midpoint Rule for triple integrals (Exercise 24) to estimate the value of the integral. Divide  $B$  into eight sub-boxes of equal size.

25.  $\iiint_B \cos(xyz) dV$ , where

$$B = \{(x, y, z) \mid 0 \leq x \leq 1, 0 \leq y \leq 1, 0 \leq z \leq 1\}$$

26.  $\iiint_B \sqrt{x} e^{xyz} dV$ , where

$$B = \{(x, y, z) \mid 0 \leq x \leq 4, 0 \leq y \leq 1, 0 \leq z \leq 2\}$$

27–28 Sketch the solid whose volume is given by the iterated integral.

27.  $\int_0^1 \int_0^{1-x} \int_0^{2-2z} dy dz dx$     28.  $\int_0^2 \int_0^{2-y} \int_0^{4-y^2} dx dz dy$

29–32 Express the integral  $\iiint_E f(x, y, z) dV$  as an iterated integral in six different ways, where  $E$  is the solid bounded by the given surfaces.

29.  $y = 4 - x^2 - 4z^2, y = 0$

30.  $y^2 + z^2 = 9, \quad x = -2, \quad x = 2$

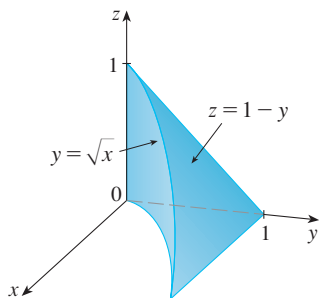
31.  $y = x^2, \quad z = 0, \quad y + 2z = 4$

32.  $x = 2, \quad y = 2, \quad z = 0, \quad x + y - 2z = 2$

33. The figure shows the region of integration for the integral

$$\int_0^1 \int_{\sqrt{x}}^1 \int_0^{1-y} f(x, y, z) \, dz \, dy \, dx$$

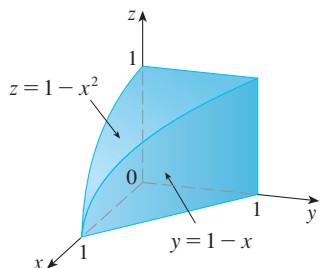
Rewrite this integral as an equivalent iterated integral in the five other orders.



34. The figure shows the region of integration for the integral

$$\int_0^1 \int_0^{1-x^2} \int_0^{1-x} f(x, y, z) \, dy \, dz \, dx$$

Rewrite this integral as an equivalent iterated integral in the five other orders.



35–36 Write five other iterated integrals that are equal to the given iterated integral.

35.  $\int_0^1 \int_y^1 \int_0^y f(x, y, z) \, dz \, dx \, dy$

36.  $\int_0^1 \int_y^1 \int_0^z f(x, y, z) \, dx \, dz \, dy$

37–38 Evaluate the triple integral using only geometric interpretation and symmetry.

37.  $\iiint_C (4 + 5x^2yz^2) \, dV$ , where  $C$  is the cylindrical region  $x^2 + y^2 \leq 4, -2 \leq z \leq 2$

38.  $\iiint_B (z^3 + \sin y + 3) \, dV$ , where  $B$  is the unit ball  $x^2 + y^2 + z^2 \leq 1$

39–42 Find the mass and center of mass of the solid  $E$  with the given density function  $\rho$ .

39.  $E$  is the solid of Exercise 13;  $\rho(x, y, z) = 2$

40.  $E$  is bounded by the parabolic cylinder  $z = 1 - y^2$  and the planes  $x + z = 1, x = 0$ , and  $z = 0$ ;  $\rho(x, y, z) = 4$

41.  $E$  is the cube given by  $0 \leq x \leq a, 0 \leq y \leq a, 0 \leq z \leq a$ ;  $\rho(x, y, z) = x^2 + y^2 + z^2$

42.  $E$  is the tetrahedron bounded by the planes  $x = 0, y = 0, z = 0, x + y + z = 1$ ;  $\rho(x, y, z) = y$

43–46 Assume that the solid has constant density  $k$ .43. Find the moments of inertia for a cube with side length  $L$  if one vertex is located at the origin and three edges lie along the coordinate axes.44. Find the moments of inertia for a rectangular brick with dimensions  $a, b$ , and  $c$  and mass  $M$  if the center of the brick is situated at the origin and the edges are parallel to the coordinate axes.45. Find the moment of inertia about the  $z$ -axis of the solid cylinder  $x^2 + y^2 \leq a^2, 0 \leq z \leq h$ .46. Find the moment of inertia about the  $z$ -axis of the solid cone  $\sqrt{x^2 + y^2} \leq z \leq h$ .47–48 Set up, but do not evaluate, integral expressions for (a) the mass, (b) the center of mass, and (c) the moment of inertia about the  $z$ -axis.

47. The solid of Exercise 21;  $\rho(x, y, z) = \sqrt{x^2 + y^2}$

48. The hemisphere  $x^2 + y^2 + z^2 \leq 1, z \geq 0$ ;  $\rho(x, y, z) = \sqrt{x^2 + y^2 + z^2}$

**CAS** 49. Let  $E$  be the solid in the first octant bounded by the cylinder  $x^2 + y^2 = 1$  and the planes  $y = z, x = 0$ , and  $z = 0$  with the density function  $\rho(x, y, z) = 1 + x + y + z$ . Use a computer algebra system to find the exact values of the following quantities for  $E$ .

- (a) The mass  
 (b) The center of mass  
 (c) The moment of inertia about the  $z$ -axis

**CAS** 50. If  $E$  is the solid of Exercise 18 with density function  $\rho(x, y, z) = x^2 + y^2$ , find the following quantities, correct to three decimal places.

- (a) The mass  
 (b) The center of mass  
 (c) The moment of inertia about the  $z$ -axis

51. The joint density function for random variables  $X$ ,  $Y$ , and  $Z$  is  $f(x, y, z) = Cxyz$  if  $0 \leq x \leq 2$ ,  $0 \leq y \leq 2$ ,  $0 \leq z \leq 2$ , and  $f(x, y, z) = 0$  otherwise.
- Find the value of the constant  $C$ .
  - Find  $P(X \leq 1, Y \leq 1, Z \leq 1)$ .
  - Find  $P(X + Y + Z \leq 1)$ .
52. Suppose  $X$ ,  $Y$ , and  $Z$  are random variables with joint density function  $f(x, y, z) = Ce^{-(0.5x+0.2y+0.1z)}$  if  $x \geq 0$ ,  $y \geq 0$ ,  $z \geq 0$ , and  $f(x, y, z) = 0$  otherwise.
- Find the value of the constant  $C$ .
  - Find  $P(X \leq 1, Y \leq 1)$ .
  - Find  $P(X \leq 1, Y \leq 1, Z \leq 1)$ .

53–54 The **average value** of a function  $f(x, y, z)$  over a solid region  $E$  is defined to be

$$f_{\text{ave}} = \frac{1}{V(E)} \iiint_E f(x, y, z) \, dV$$

where  $V(E)$  is the volume of  $E$ . For instance, if  $\rho$  is a density function, then  $\rho_{\text{ave}}$  is the average density of  $E$ .

53. Find the average value of the function  $f(x, y, z) = xyz$  over the cube with side length  $L$  that lies in the first octant with one vertex at the origin and edges parallel to the coordinate axes.
54. Find the average value of the function  $f(x, y, z) = x^2z + y^2z$  over the region enclosed by the paraboloid  $z = 1 - x^2 - y^2$  and the plane  $z = 0$ .

55. (a) Find the region  $E$  for which the triple integral

$$\iiint_E (1 - x^2 - 2y^2 - 3z^2) \, dV$$

is a maximum.

- (b) Use a computer algebra system to calculate the exact maximum value of the triple integral in part (a).

## DISCOVERY PROJECT

## VOLUMES OF HYPERSPHERES

In this project we find formulas for the volume enclosed by a hypersphere in  $n$ -dimensional space.

- Use a double integral and trigonometric substitution, together with Formula 64 in the Table of Integrals, to find the area of a circle with radius  $r$ .
- Use a triple integral and trigonometric substitution to find the volume of a sphere with radius  $r$ .
- Use a quadruple integral to find the hypervolume enclosed by the hypersphere  $x^2 + y^2 + z^2 + w^2 = r^2$  in  $\mathbb{R}^4$ . (Use only trigonometric substitution and the reduction formulas for  $\int \sin^n x \, dx$  or  $\int \cos^n x \, dx$ .)
- Use an  $n$ -tuple integral to find the volume enclosed by a hypersphere of radius  $r$  in  $n$ -dimensional space  $\mathbb{R}^n$ . [Hint: The formulas are different for  $n$  even and  $n$  odd.]

## 15.8 Triple Integrals in Cylindrical Coordinates

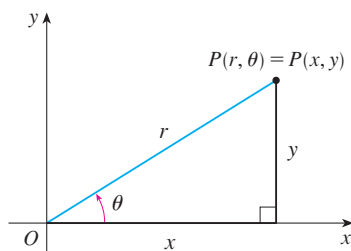
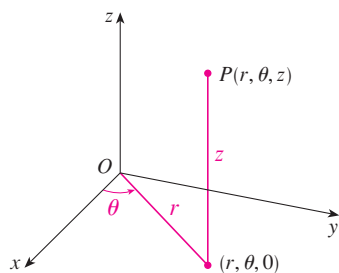


FIGURE 1

In plane geometry the polar coordinate system is used to give a convenient description of certain curves and regions. (See Section 10.3.) Figure 1 enables us to recall the connection between polar and Cartesian coordinates. If the point  $P$  has Cartesian coordinates  $(x, y)$  and polar coordinates  $(r, \theta)$ , then, from the figure,

$$\begin{aligned} x &= r \cos \theta & y &= r \sin \theta \\ r^2 &= x^2 + y^2 & \tan \theta &= \frac{y}{x} \end{aligned}$$

In three dimensions there is a coordinate system, called *cylindrical coordinates*, that is similar to polar coordinates and gives convenient descriptions of some commonly occurring surfaces and solids. As we will see, some triple integrals are much easier to evaluate in cylindrical coordinates.



**FIGURE 2**  
The cylindrical coordinates of a point

## Cylindrical Coordinates

In the **cylindrical coordinate system**, a point  $P$  in three-dimensional space is represented by the ordered triple  $(r, \theta, z)$ , where  $r$  and  $\theta$  are polar coordinates of the projection of  $P$  onto the  $xy$ -plane and  $z$  is the directed distance from the  $xy$ -plane to  $P$ . (See Figure 2.)

To convert from cylindrical to rectangular coordinates, we use the equations

$$1 \quad x = r \cos \theta \quad y = r \sin \theta \quad z = z$$

whereas to convert from rectangular to cylindrical coordinates, we use

$$2 \quad r^2 = x^2 + y^2 \quad \tan \theta = \frac{y}{x} \quad z = z$$

### EXAMPLE 1

- (a) Plot the point with cylindrical coordinates  $(2, 2\pi/3, 1)$  and find its rectangular coordinates.  
 (b) Find cylindrical coordinates of the point with rectangular coordinates  $(3, -3, -7)$ .

#### SOLUTION

(a) The point with cylindrical coordinates  $(2, 2\pi/3, 1)$  is plotted in Figure 3. From Equations 1, its rectangular coordinates are

$$x = 2 \cos \frac{2\pi}{3} = 2 \left( -\frac{1}{2} \right) = -1$$

$$y = 2 \sin \frac{2\pi}{3} = 2 \left( \frac{\sqrt{3}}{2} \right) = \sqrt{3}$$

$$z = 1$$

Thus the point is  $(-1, \sqrt{3}, 1)$  in rectangular coordinates.

(b) From Equations 2 we have

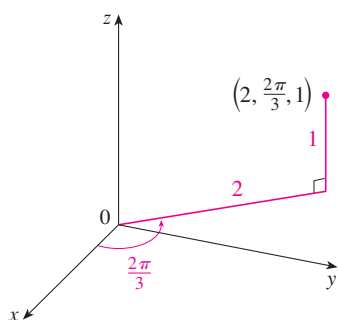
$$r = \sqrt{3^2 + (-3)^2} = 3\sqrt{2}$$

$$\tan \theta = \frac{-3}{3} = -1 \quad \text{so} \quad \theta = \frac{7\pi}{4} + 2n\pi$$

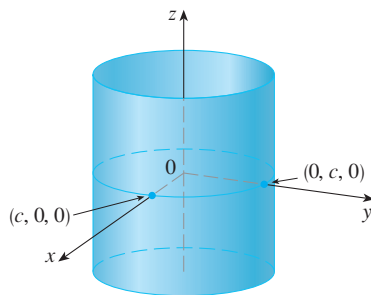
$$z = -7$$

Therefore one set of cylindrical coordinates is  $(3\sqrt{2}, 7\pi/4, -7)$ . Another is  $(3\sqrt{2}, -\pi/4, -7)$ . As with polar coordinates, there are infinitely many choices.

Cylindrical coordinates are useful in problems that involve symmetry about an axis, and the  $z$ -axis is chosen to coincide with this axis of symmetry. For instance, the axis of the circular cylinder with Cartesian equation  $x^2 + y^2 = c^2$  is the  $z$ -axis. In cylindrical coordinates this cylinder has the very simple equation  $r = c$ . (See Figure 4.) This is the reason for the name “cylindrical” coordinates.

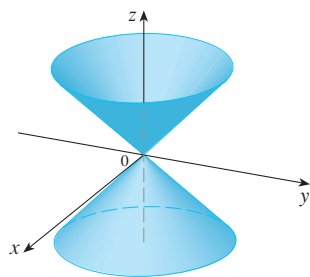


**FIGURE 3**



**FIGURE 4**  
 $r = c$ , a cylinder





**FIGURE 5**  
 $z = r$ , a cone

**V EXAMPLE 2** Describe the surface whose equation in cylindrical coordinates is  $z = r$ .

**SOLUTION** The equation says that the  $z$ -value, or height, of each point on the surface is the same as  $r$ , the distance from the point to the  $z$ -axis. Because  $\theta$  doesn't appear, it can vary. So any horizontal trace in the plane  $z = k$  ( $k > 0$ ) is a circle of radius  $k$ . These traces suggest that the surface is a cone. This prediction can be confirmed by converting the equation into rectangular coordinates. From the first equation in [2] we have

$$z^2 = r^2 = x^2 + y^2$$

We recognize the equation  $z^2 = x^2 + y^2$  (by comparison with Table 1 in Section 12.6) as being a circular cone whose axis is the  $z$ -axis (see Figure 5).

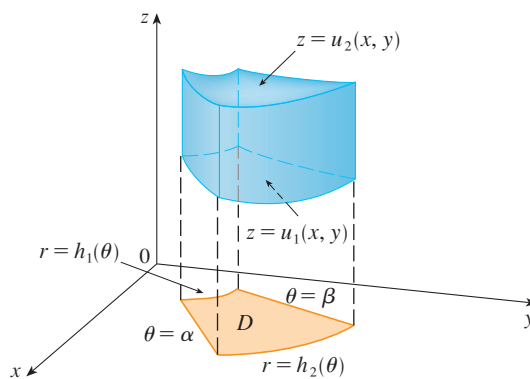
### Evaluating Triple Integrals with Cylindrical Coordinates

Suppose that  $E$  is a type 1 region whose projection  $D$  onto the  $xy$ -plane is conveniently described in polar coordinates (see Figure 6). In particular, suppose that  $f$  is continuous and

$$E = \{(x, y, z) \mid (x, y) \in D, u_1(x, y) \leq z \leq u_2(x, y)\}$$

where  $D$  is given in polar coordinates by

$$D = \{(r, \theta) \mid \alpha \leq \theta \leq \beta, h_1(\theta) \leq r \leq h_2(\theta)\}$$



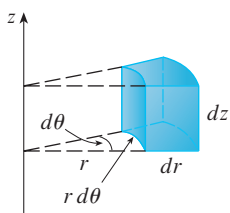
**FIGURE 6**

We know from Equation 15.7.6 that

$$\boxed{3} \quad \iiint_E f(x, y, z) \, dV = \iint_D \left[ \int_{u_1(x, y)}^{u_2(x, y)} f(x, y, z) \, dz \right] dA$$

But we also know how to evaluate double integrals in polar coordinates. In fact, combining Equation 3 with Equation 15.4.3, we obtain

$$\boxed{4} \quad \iiint_E f(x, y, z) \, dV = \int_{\alpha}^{\beta} \int_{h_1(\theta)}^{h_2(\theta)} \int_{u_1(r \cos \theta, r \sin \theta)}^{u_2(r \cos \theta, r \sin \theta)} f(r \cos \theta, r \sin \theta, z) \, r \, dz \, dr \, d\theta$$



**FIGURE 7**  
Volume element in cylindrical coordinates:  $dV = r \, dz \, dr \, d\theta$

Formula 4 is the **formula for triple integration in cylindrical coordinates**. It says that we convert a triple integral from rectangular to cylindrical coordinates by writing  $x = r \cos \theta$ ,  $y = r \sin \theta$ , leaving  $z$  as it is, using the appropriate limits of integration for  $z$ ,  $r$ , and  $\theta$ , and replacing  $dV$  by  $r \, dz \, dr \, d\theta$ . (Figure 7 shows how to remember this.) It is worthwhile to use this formula when  $E$  is a solid region easily described in cylindrical coordinates, and especially when the function  $f(x, y, z)$  involves the expression  $x^2 + y^2$ .

**V EXAMPLE 3** A solid  $E$  lies within the cylinder  $x^2 + y^2 = 1$ , below the plane  $z = 4$ , and above the paraboloid  $z = 1 - x^2 - y^2$ . (See Figure 8.) The density at any point is proportional to its distance from the axis of the cylinder. Find the mass of  $E$ .

**SOLUTION** In cylindrical coordinates the cylinder is  $r = 1$  and the paraboloid is  $z = 1 - r^2$ , so we can write

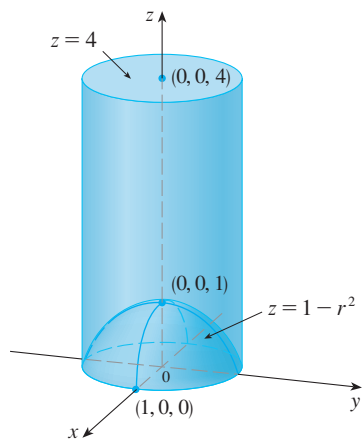
$$E = \{(r, \theta, z) \mid 0 \leq \theta \leq 2\pi, 0 \leq r \leq 1, 1 - r^2 \leq z \leq 4\}$$

Since the density at  $(x, y, z)$  is proportional to the distance from the  $z$ -axis, the density function is

$$f(x, y, z) = K\sqrt{x^2 + y^2} = Kr$$

where  $K$  is the proportionality constant. Therefore, from Formula 15.7.13, the mass of  $E$  is

$$\begin{aligned} m &= \iiint_E K\sqrt{x^2 + y^2} \, dV = \int_0^{2\pi} \int_0^1 \int_{1-r^2}^4 (Kr) \, r \, dz \, dr \, d\theta \\ &= \int_0^{2\pi} \int_0^1 Kr^2 [4 - (1 - r^2)] \, dr \, d\theta = K \int_0^{2\pi} d\theta \int_0^1 (3r^2 + r^4) \, dr \\ &= 2\pi K \left[ r^3 + \frac{r^5}{5} \right]_0^1 = \frac{12\pi K}{5} \end{aligned}$$



**FIGURE 8**

**EXAMPLE 4** Evaluate  $\int_{-2}^2 \int_{-\sqrt{4-x^2}}^{\sqrt{4-x^2}} \int_{\sqrt{x^2+y^2}}^2 (x^2 + y^2) \, dz \, dy \, dx$ .

**SOLUTION** This iterated integral is a triple integral over the solid region

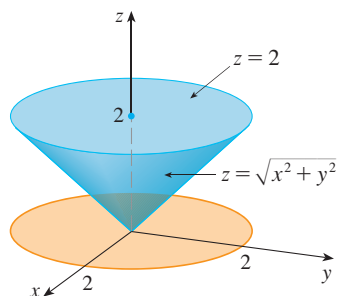
$$E = \{(x, y, z) \mid -2 \leq x \leq 2, -\sqrt{4-x^2} \leq y \leq \sqrt{4-x^2}, \sqrt{x^2 + y^2} \leq z \leq 2\}$$

and the projection of  $E$  onto the  $xy$ -plane is the disk  $x^2 + y^2 \leq 4$ . The lower surface of  $E$  is the cone  $z = \sqrt{x^2 + y^2}$  and its upper surface is the plane  $z = 2$ . (See Figure 9.) This region has a much simpler description in cylindrical coordinates:

$$E = \{(r, \theta, z) \mid 0 \leq \theta \leq 2\pi, 0 \leq r \leq 2, r \leq z \leq 2\}$$

Therefore we have

$$\begin{aligned} \int_{-2}^2 \int_{-\sqrt{4-x^2}}^{\sqrt{4-x^2}} \int_{\sqrt{x^2+y^2}}^2 (x^2 + y^2) \, dz \, dy \, dx &= \iiint_E (x^2 + y^2) \, dV \\ &= \int_0^{2\pi} \int_0^2 \int_r^2 r^2 \, r \, dz \, dr \, d\theta \\ &= \int_0^{2\pi} d\theta \int_0^2 r^3 (2 - r) \, dr \\ &= 2\pi \left[ \frac{1}{2} r^4 - \frac{1}{5} r^5 \right]_0^2 = \frac{16}{5} \pi \end{aligned}$$



**FIGURE 9**

## 15.8 Exercises

1–2 Plot the point whose cylindrical coordinates are given. Then find the rectangular coordinates of the point.

1. (a)  $(4, \pi/3, -2)$  (b)  $(2, -\pi/2, 1)$   
 2. (a)  $(\sqrt{2}, 3\pi/4, 2)$  (b)  $(1, 1, 1)$

3–4 Change from rectangular to cylindrical coordinates.

3. (a)  $(-1, 1, 1)$  (b)  $(-2, 2\sqrt{3}, 3)$   
 4. (a)  $(2\sqrt{3}, 2, -1)$  (b)  $(4, -3, 2)$

5–6 Describe in words the surface whose equation is given.

5.  $\theta = \pi/4$  6.  $r = 5$

7–8 Identify the surface whose equation is given.

7.  $z = 4 - r^2$  8.  $2r^2 + z^2 = 1$


9–10 Write the equations in cylindrical coordinates.

9. (a)  $x^2 - x + y^2 + z^2 = 1$  (b)  $z = x^2 - y^2$   
 10. (a)  $3x + 2y + z = 6$  (b)  $-x^2 - y^2 + z^2 = 1$

11–12 Sketch the solid described by the given inequalities.

11.  $0 \leq r \leq 2, -\pi/2 \leq \theta \leq \pi/2, 0 \leq z \leq 1$   
 12.  $0 \leq \theta \leq \pi/2, r \leq z \leq 2$

13. A cylindrical shell is 20 cm long, with inner radius 6 cm and outer radius 7 cm. Write inequalities that describe the shell in an appropriate coordinate system. Explain how you have positioned the coordinate system with respect to the shell.

-  14. Use a graphing device to draw the solid enclosed by the paraboloids  $z = x^2 + y^2$  and  $z = 5 - x^2 - y^2$ .

15–16 Sketch the solid whose volume is given by the integral and evaluate the integral.

15.  $\int_{-\pi/2}^{\pi/2} \int_0^2 \int_0^{r^2} r \, dz \, dr \, d\theta$  16.  $\int_0^2 \int_0^{2\pi} \int_0^r r \, dz \, d\theta \, dr$

17–28 Use cylindrical coordinates.

17. Evaluate  $\iiint_E \sqrt{x^2 + y^2} \, dV$ , where  $E$  is the region that lies inside the cylinder  $x^2 + y^2 = 16$  and between the planes  $z = -5$  and  $z = 4$ .

18. Evaluate  $\iiint_E z \, dV$ , where  $E$  is enclosed by the paraboloid  $z = x^2 + y^2$  and the plane  $z = 4$ .

19. Evaluate  $\iiint_E (x + y + z) \, dV$ , where  $E$  is the solid in the first octant that lies under the paraboloid  $z = 4 - x^2 - y^2$ .

20. Evaluate  $\iiint_E x \, dV$ , where  $E$  is enclosed by the planes  $z = 0$  and  $z = x + y + 5$  and by the cylinders  $x^2 + y^2 = 4$  and  $x^2 + y^2 = 9$ .

21. Evaluate  $\iiint_E x^2 \, dV$ , where  $E$  is the solid that lies within the cylinder  $x^2 + y^2 = 1$ , above the plane  $z = 0$ , and below the cone  $z^2 = 4x^2 + 4y^2$ .

22. Find the volume of the solid that lies within both the cylinder  $x^2 + y^2 = 1$  and the sphere  $x^2 + y^2 + z^2 = 4$ .

23. Find the volume of the solid that is enclosed by the cone  $z = \sqrt{x^2 + y^2}$  and the sphere  $x^2 + y^2 + z^2 = 2$ .

24. Find the volume of the solid that lies between the paraboloid  $z = x^2 + y^2$  and the sphere  $x^2 + y^2 + z^2 = 2$ .

25. (a) Find the volume of the region  $E$  bounded by the paraboloids  $z = x^2 + y^2$  and  $z = 36 - 3x^2 - 3y^2$ .  
 (b) Find the centroid of  $E$  (the center of mass in the case where the density is constant).

26. (a) Find the volume of the solid that the cylinder  $r = a \cos \theta$  cuts out of the sphere of radius  $a$  centered at the origin.



- (b) Illustrate the solid of part (a) by graphing the sphere and the cylinder on the same screen.

27. Find the mass and center of mass of the solid  $S$  bounded by the paraboloid  $z = 4x^2 + 4y^2$  and the plane  $z = a$  ( $a > 0$ ) if  $S$  has constant density  $K$ .

28. Find the mass of a ball  $B$  given by  $x^2 + y^2 + z^2 \leq a^2$  if the density at any point is proportional to its distance from the  $z$ -axis.

29–30 Evaluate the integral by changing to cylindrical coordinates.

29.  $\int_{-2}^2 \int_{-\sqrt{4-y^2}}^{\sqrt{4-y^2}} \int_{\sqrt{x^2+y^2}}^2 xz \, dz \, dx \, dy$

30.  $\int_{-3}^3 \int_0^{\sqrt{9-x^2}} \int_0^{9-x^2-y^2} \sqrt{x^2 + y^2} \, dz \, dy \, dx$

31. When studying the formation of mountain ranges, geologists estimate the amount of work required to lift a mountain from sea level. Consider a mountain that is essentially in the shape of a right circular cone. Suppose that the weight density of the material in the vicinity of a point  $P$  is  $g(P)$  and the height is  $h(P)$ .

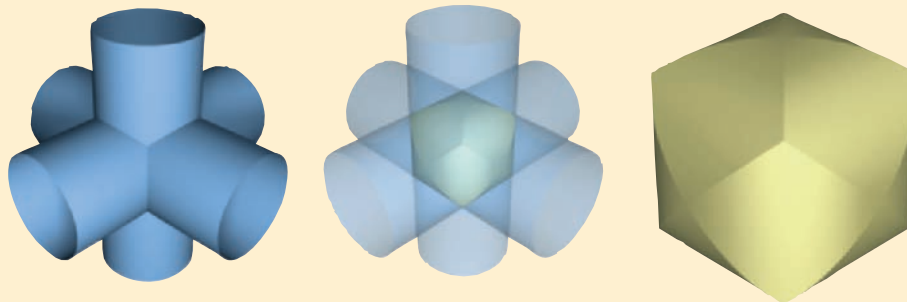
- (a) Find a definite integral that represents the total work done in forming the mountain.
- (b) Assume that Mount Fuji in Japan is in the shape of a right circular cone with radius 62,000 ft, height 12,400 ft, and density a constant 200 lb/ft<sup>3</sup>. How much work was done in forming Mount Fuji if the land was initially at sea level?



© S.R. Lee Photo Traveller / Shutterstock

## LABORATORY PROJECT THE INTERSECTION OF THREE CYLINDERS

The figure shows the solid enclosed by three circular cylinders with the same diameter that intersect at right angles. In this project we compute its volume and determine how its shape changes if the cylinders have different diameters.

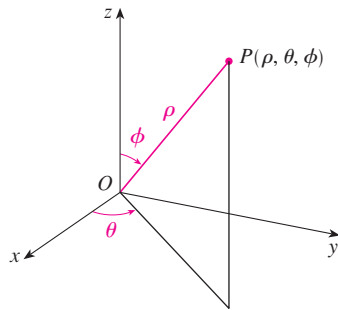


1. Sketch carefully the solid enclosed by the three cylinders  $x^2 + y^2 = 1$ ,  $x^2 + z^2 = 1$ , and  $y^2 + z^2 = 1$ . Indicate the positions of the coordinate axes and label the faces with the equations of the corresponding cylinders.
2. Find the volume of the solid in Problem 1.
- CAS** 3. Use a computer algebra system to draw the edges of the solid.
4. What happens to the solid in Problem 1 if the radius of the first cylinder is different from 1? Illustrate with a hand-drawn sketch or a computer graph.
5. If the first cylinder is  $x^2 + y^2 = a^2$ , where  $a < 1$ , set up, but do not evaluate, a double integral for the volume of the solid. What if  $a > 1$ ?

**CAS** Computer algebra system required

## 15.9 Triple Integrals in Spherical Coordinates

Another useful coordinate system in three dimensions is the *spherical coordinate system*. It simplifies the evaluation of triple integrals over regions bounded by spheres or cones.



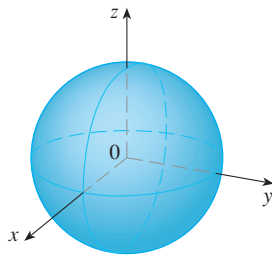
**FIGURE 1**  
The spherical coordinates of a point

### Spherical Coordinates

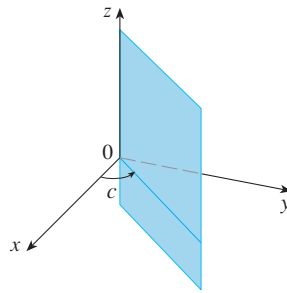
The **spherical coordinates**  $(\rho, \theta, \phi)$  of a point  $P$  in space are shown in Figure 1, where  $\rho = |OP|$  is the distance from the origin to  $P$ ,  $\theta$  is the same angle as in cylindrical coordinates, and  $\phi$  is the angle between the positive  $z$ -axis and the line segment  $OP$ . Note that

$$\rho \geq 0 \quad 0 \leq \phi \leq \pi$$

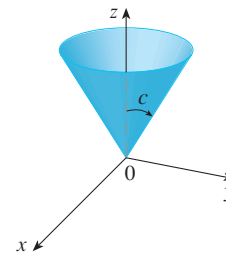
The spherical coordinate system is especially useful in problems where there is symmetry about a point, and the origin is placed at this point. For example, the sphere with center the origin and radius  $c$  has the simple equation  $\rho = c$  (see Figure 2); this is the reason for the name “spherical” coordinates. The graph of the equation  $\theta = c$  is a vertical half-plane (see Figure 3), and the equation  $\phi = c$  represents a half-cone with the  $z$ -axis as its axis (see Figure 4).



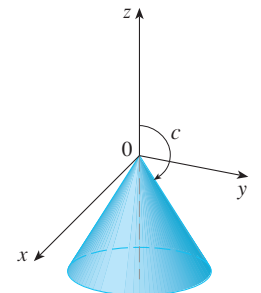
**FIGURE 2**  $\rho = c$ , a sphere



**FIGURE 3**  $\theta = c$ , a half-plane

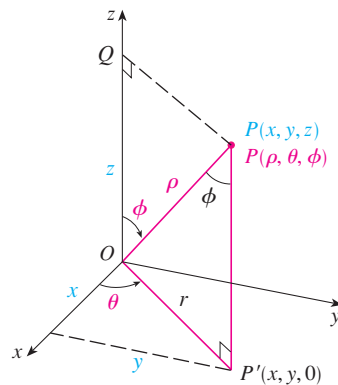


$$0 < c < \pi/2$$



$$\pi/2 < c < \pi$$

**FIGURE 4**  $\phi = c$ , a half-cone



**FIGURE 5**

The relationship between rectangular and spherical coordinates can be seen from Figure 5. From triangles  $OPQ$  and  $OPP'$  we have

$$z = \rho \cos \phi \quad r = \rho \sin \phi$$

But  $x = r \cos \theta$  and  $y = r \sin \theta$ , so to convert from spherical to rectangular coordinates, we use the equations

$$\boxed{1} \quad x = \rho \sin \phi \cos \theta \quad y = \rho \sin \phi \sin \theta \quad z = \rho \cos \phi$$

Also, the distance formula shows that

$$\boxed{2} \quad \rho^2 = x^2 + y^2 + z^2$$

We use this equation in converting from rectangular to spherical coordinates.

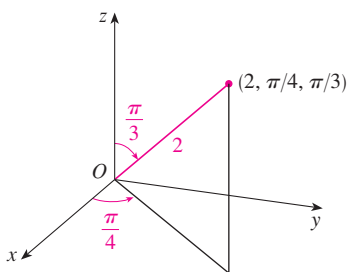


FIGURE 6

**V EXAMPLE 1** The point  $(2, \pi/4, \pi/3)$  is given in spherical coordinates. Plot the point and find its rectangular coordinates.

**SOLUTION** We plot the point in Figure 6. From Equations 1 we have

$$x = \rho \sin \phi \cos \theta = 2 \sin \frac{\pi}{3} \cos \frac{\pi}{4} = 2 \left( \frac{\sqrt{3}}{2} \right) \left( \frac{1}{\sqrt{2}} \right) = \sqrt{\frac{3}{2}}$$

$$y = \rho \sin \phi \sin \theta = 2 \sin \frac{\pi}{3} \sin \frac{\pi}{4} = 2 \left( \frac{\sqrt{3}}{2} \right) \left( \frac{1}{\sqrt{2}} \right) = \sqrt{\frac{3}{2}}$$

$$z = \rho \cos \phi = 2 \cos \frac{\pi}{3} = 2 \left( \frac{1}{2} \right) = 1$$

Thus the point  $(2, \pi/4, \pi/3)$  is  $(\sqrt{3/2}, \sqrt{3/2}, 1)$  in rectangular coordinates.  

**V EXAMPLE 2** The point  $(0, 2\sqrt{3}, -2)$  is given in rectangular coordinates. Find spherical coordinates for this point.

**SOLUTION** From Equation 2 we have

$$\rho = \sqrt{x^2 + y^2 + z^2} = \sqrt{0 + 12 + 4} = 4$$

and so Equations 1 give

$$\cos \phi = \frac{z}{\rho} = \frac{-2}{4} = -\frac{1}{2} \quad \phi = \frac{2\pi}{3}$$

$$\cos \theta = \frac{x}{\rho \sin \phi} = 0 \quad \theta = \frac{\pi}{2}$$

(Note that  $\theta \neq 3\pi/2$  because  $y = 2\sqrt{3} > 0$ .) Therefore spherical coordinates of the given point are  $(4, \pi/2, 2\pi/3)$ .  

**WARNING** There is not universal agreement on the notation for spherical coordinates. Most books on physics reverse the meanings of  $\theta$  and  $\phi$  and use  $r$  in place of  $\rho$ .

**TEC** In Module 15.9 you can investigate families of surfaces in cylindrical and spherical coordinates.

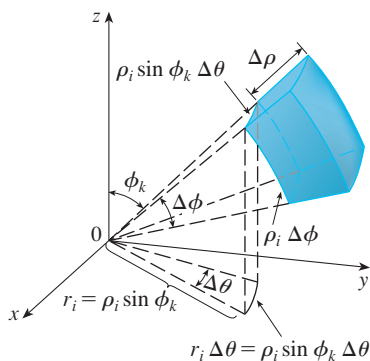


FIGURE 7

### Evaluating Triple Integrals with Spherical Coordinates

In the spherical coordinate system the counterpart of a rectangular box is a **spherical wedge**

$$E = \{(\rho, \theta, \phi) \mid a \leq \rho \leq b, \alpha \leq \theta \leq \beta, c \leq \phi \leq d\}$$

where  $a \geq 0$  and  $\beta - \alpha \leq 2\pi$ , and  $d - c \leq \pi$ . Although we defined triple integrals by dividing solids into small boxes, it can be shown that dividing a solid into small spherical wedges always gives the same result. So we divide  $E$  into smaller spherical wedges  $E_{ijk}$  by means of equally spaced spheres  $\rho = \rho_i$ , half-planes  $\theta = \theta_j$ , and half-cones  $\phi = \phi_k$ . Figure 7 shows that  $E_{ijk}$  is approximately a rectangular box with dimensions  $\Delta\rho$ ,  $\rho_i \Delta\phi$  (arc of a circle with radius  $\rho_i$ , angle  $\Delta\phi$ ), and  $\rho_i \sin \phi_k \Delta\theta$  (arc of a circle with radius  $\rho_i \sin \phi_k$ , angle  $\Delta\theta$ ). So an approximation to the volume of  $E_{ijk}$  is given by

$$\Delta V_{ijk} \approx (\Delta\rho)(\rho_i \Delta\phi)(\rho_i \sin \phi_k \Delta\theta) = \rho_i^2 \sin \phi_k \Delta\rho \Delta\theta \Delta\phi$$

In fact, it can be shown, with the aid of the Mean Value Theorem (Exercise 47), that the volume of  $E_{ijk}$  is given exactly by

$$\Delta V_{ijk} = \bar{\rho}_i^2 \sin \bar{\phi}_k \Delta\rho \Delta\theta \Delta\phi$$

where  $(\bar{\rho}_i, \bar{\theta}_j, \bar{\phi}_k)$  is some point in  $E_{ijk}$ . Let  $(x_{ijk}^*, y_{ijk}^*, z_{ijk}^*)$  be the rectangular coordinates of this point. Then

$$\begin{aligned} \iiint_E f(x, y, z) dV &= \lim_{l, m, n \rightarrow \infty} \sum_{i=1}^l \sum_{j=1}^m \sum_{k=1}^n f(x_{ijk}^*, y_{ijk}^*, z_{ijk}^*) \Delta V_{ijk} \\ &= \lim_{l, m, n \rightarrow \infty} \sum_{i=1}^l \sum_{j=1}^m \sum_{k=1}^n f(\bar{\rho}_i \sin \bar{\phi}_k \cos \bar{\theta}_j, \bar{\rho}_i \sin \bar{\phi}_k \sin \bar{\theta}_j, \bar{\rho}_i \cos \bar{\phi}_k) \bar{\rho}_i^2 \sin \bar{\phi}_k \Delta \rho \Delta \theta \Delta \phi \end{aligned}$$

But this sum is a Riemann sum for the function

$$F(\rho, \theta, \phi) = f(\rho \sin \phi \cos \theta, \rho \sin \phi \sin \theta, \rho \cos \phi) \rho^2 \sin \phi$$

Consequently, we have arrived at the following **formula for triple integration in spherical coordinates**.

$$\begin{aligned} \text{3} \quad \iiint_E f(x, y, z) dV &= \int_c^d \int_\alpha^\beta \int_a^b f(\rho \sin \phi \cos \theta, \rho \sin \phi \sin \theta, \rho \cos \phi) \rho^2 \sin \phi d\rho d\theta d\phi \end{aligned}$$

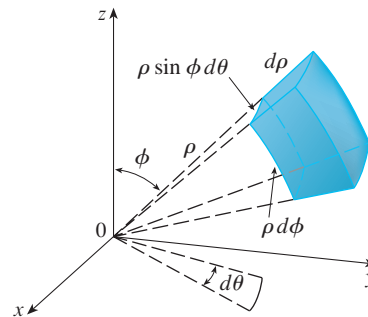
where  $E$  is a spherical wedge given by

$$E = \{(\rho, \theta, \phi) \mid a \leq \rho \leq b, \alpha \leq \theta \leq \beta, c \leq \phi \leq d\}$$

Formula 3 says that we convert a triple integral from rectangular coordinates to spherical coordinates by writing

$$x = \rho \sin \phi \cos \theta \quad y = \rho \sin \phi \sin \theta \quad z = \rho \cos \phi$$

using the appropriate limits of integration, and replacing  $dV$  by  $\rho^2 \sin \phi d\rho d\theta d\phi$ . This is illustrated in Figure 8.



**FIGURE 8**  
Volume element in spherical coordinates:  $dV = \rho^2 \sin \phi d\rho d\theta d\phi$

This formula can be extended to include more general spherical regions such as

$$E = \{(\rho, \theta, \phi) \mid \alpha \leq \theta \leq \beta, c \leq \phi \leq d, g_1(\theta, \phi) \leq \rho \leq g_2(\theta, \phi)\}$$

In this case the formula is the same as in [3] except that the limits of integration for  $\rho$  are  $g_1(\theta, \phi)$  and  $g_2(\theta, \phi)$ .

Usually, spherical coordinates are used in triple integrals when surfaces such as cones and spheres form the boundary of the region of integration.

**V EXAMPLE 3** Evaluate  $\iiint_B e^{(x^2+y^2+z^2)^{3/2}} dV$ , where  $B$  is the unit ball:

$$B = \{(x, y, z) \mid x^2 + y^2 + z^2 \leq 1\}$$

**SOLUTION** Since the boundary of  $B$  is a sphere, we use spherical coordinates:

$$B = \{(\rho, \theta, \phi) \mid 0 \leq \rho \leq 1, 0 \leq \theta \leq 2\pi, 0 \leq \phi \leq \pi\}$$

In addition, spherical coordinates are appropriate because

$$x^2 + y^2 + z^2 = \rho^2$$

Thus [3] gives

$$\begin{aligned} \iiint_B e^{(x^2+y^2+z^2)^{3/2}} dV &= \int_0^\pi \int_0^{2\pi} \int_0^1 e^{(\rho^2)^{3/2}} \rho^2 \sin \phi \, d\rho \, d\theta \, d\phi \\ &= \int_0^\pi \sin \phi \, d\phi \int_0^{2\pi} d\theta \int_0^1 \rho^2 e^{\rho^3} \, d\rho \\ &= [-\cos \phi]_0^\pi (2\pi) \left[\frac{1}{3}e^{\rho^3}\right]_0^1 = \frac{4}{3}\pi(e - 1) \end{aligned}$$

**NOTE** It would have been extremely awkward to evaluate the integral in Example 3 without spherical coordinates. In rectangular coordinates the iterated integral would have been

$$\int_{-1}^1 \int_{-\sqrt{1-x^2}}^{\sqrt{1-x^2}} \int_{-\sqrt{1-x^2-y^2}}^{\sqrt{1-x^2-y^2}} e^{(x^2+y^2+z^2)^{3/2}} dz \, dy \, dx$$

**V EXAMPLE 4** Use spherical coordinates to find the volume of the solid that lies above the cone  $z = \sqrt{x^2 + y^2}$  and below the sphere  $x^2 + y^2 + z^2 = z$ . (See Figure 9.)

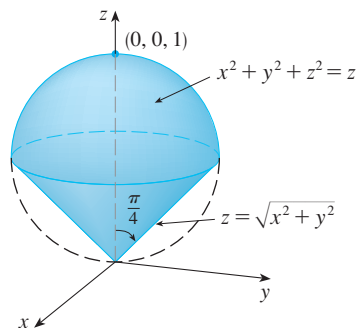


FIGURE 9

Figure 10 gives another look (this time drawn by Maple) at the solid of Example 4.

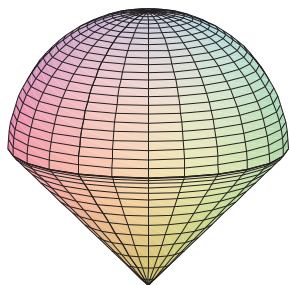


FIGURE 10

**SOLUTION** Notice that the sphere passes through the origin and has center  $(0, 0, \frac{1}{2})$ . We write the equation of the sphere in spherical coordinates as

$$\rho^2 = \rho \cos \phi \quad \text{or} \quad \rho = \cos \phi$$

The equation of the cone can be written as

$$\rho \cos \phi = \sqrt{\rho^2 \sin^2 \phi \cos^2 \theta + \rho^2 \sin^2 \phi \sin^2 \theta} = \rho \sin \phi$$

This gives  $\sin \phi = \cos \phi$ , or  $\phi = \pi/4$ . Therefore the description of the solid  $E$  in spherical coordinates is

$$E = \{(\rho, \theta, \phi) \mid 0 \leq \theta \leq 2\pi, 0 \leq \phi \leq \pi/4, 0 \leq \rho \leq \cos \phi\}$$



Figure 11 shows how  $E$  is swept out if we integrate first with respect to  $\rho$ , then  $\phi$ , and then  $\theta$ . The volume of  $E$  is

$$\begin{aligned} V(E) &= \iiint_E dV = \int_0^{2\pi} \int_0^{\pi/4} \int_0^{\cos \phi} \rho^2 \sin \phi \, d\rho \, d\phi \, d\theta \\ &= \int_0^{2\pi} d\theta \int_0^{\pi/4} \sin \phi \left[ \frac{\rho^3}{3} \right]_{\rho=0}^{\rho=\cos \phi} d\phi \\ &= \frac{2\pi}{3} \int_0^{\pi/4} \sin \phi \cos^3 \phi \, d\phi = \frac{2\pi}{3} \left[ -\frac{\cos^4 \phi}{4} \right]_0^{\pi/4} = \frac{\pi}{8} \end{aligned}$$

**TEC** Visual 15.9 shows an animation of Figure 11.

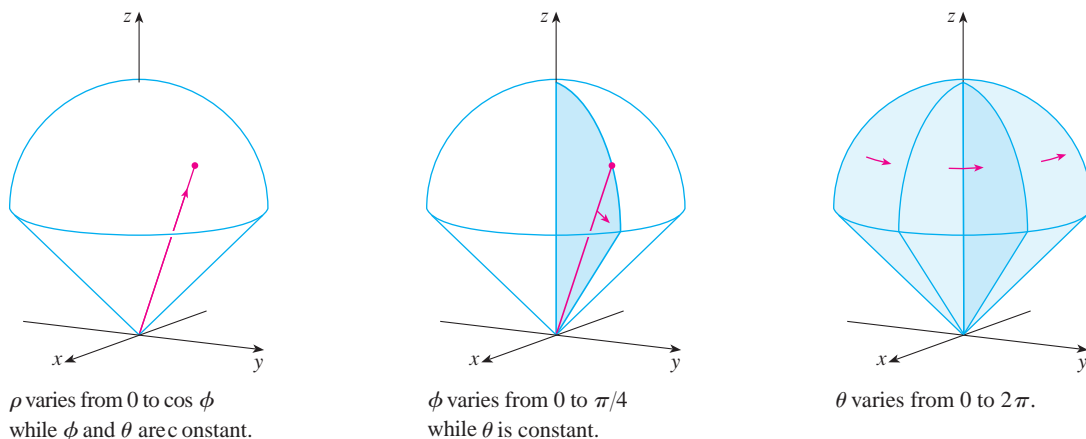


FIGURE 11

## 15.9 Exercises

**1–2** Plot the point whose spherical coordinates are given. Then find the rectangular coordinates of the point.

1. (a)  $(6, \pi/3, \pi/6)$       (b)  $(3, \pi/2, 3\pi/4)$   
2. (a)  $(2, \pi/2, \pi/2)$       (b)  $(4, -\pi/4, \pi/3)$

**3–4** Change from rectangular to spherical coordinates.

3. (a)  $(0, -2, 0)$       (b)  $(-1, 1, -\sqrt{2})$   
4. (a)  $(1, 0, \sqrt{3})$       (b)  $(\sqrt{3}, -1, 2\sqrt{3})$

**5–6** Describe in words the surface whose equation is given.

5.  $\phi = \pi/3$       6.  $\rho = 3$

**7–8** Identify the surface whose equation is given.

7.  $\rho = \sin \theta \sin \phi$       8.  $\rho^2(\sin^2 \phi \sin^2 \theta + \cos^2 \phi) = 9$

**9–10** Write the equation in spherical coordinates.

9. (a)  $z^2 = x^2 + y^2$       (b)  $x^2 + z^2 = 9$   
10. (a)  $x^2 - 2x + y^2 + z^2 = 0$       (b)  $x + 2y + 3z = 1$

**11–14** Sketch the solid described by the given inequalities.

11.  $2 \leq \rho \leq 4, \quad 0 \leq \phi \leq \pi/3, \quad 0 \leq \theta \leq \pi$   
12.  $1 \leq \rho \leq 2, \quad 0 \leq \phi \leq \pi/2, \quad \pi/2 \leq \theta \leq 3\pi/2$   
13.  $\rho \leq 1, \quad 3\pi/4 \leq \phi \leq \pi$   
14.  $\rho \leq 2, \quad \rho \leq \csc \phi$

**15.** A solid lies above the cone  $z = \sqrt{x^2 + y^2}$  and below the sphere  $x^2 + y^2 + z^2 = z$ . Write a description of the solid in terms of inequalities involving spherical coordinates.

**16.** (a) Find inequalities that describe a hollow ball with diameter 30 cm and thickness 0.5 cm. Explain how you have positioned the coordinate system that you have chosen.

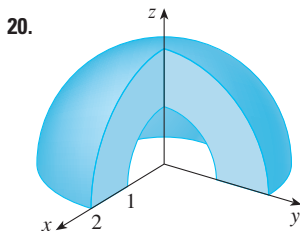
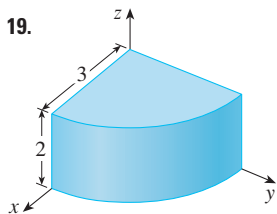
- (b) Suppose the ball is cut in half. Write inequalities that describe one of the halves.

**17–18** Sketch the solid whose volume is given by the integral and evaluate the integral.

17. 
$$\int_0^{\pi/6} \int_0^{\pi/2} \int_0^3 \rho^2 \sin \phi \, d\rho \, d\theta \, d\phi$$

18. 
$$\int_0^{2\pi} \int_{\pi/2}^{\pi} \int_1^2 \rho^2 \sin \phi \, d\rho \, d\phi \, d\theta$$

**19–20** Set up the triple integral of an arbitrary continuous function  $f(x, y, z)$  in cylindrical or spherical coordinates over the solid shown.



**21–34** Use spherical coordinates.

21. Evaluate  $\iiint_B (x^2 + y^2 + z^2)^2 \, dV$ , where  $B$  is the ball with center the origin and radius 5.
22. Evaluate  $\iiint_H (9 - x^2 - y^2) \, dV$ , where  $H$  is the solid hemisphere  $x^2 + y^2 + z^2 \leq 9$ ,  $z \geq 0$ .
23. Evaluate  $\iiint_E (x^2 + y^2) \, dV$ , where  $E$  lies between the spheres  $x^2 + y^2 + z^2 = 4$  and  $x^2 + y^2 + z^2 = 9$ .
24. Evaluate  $\iiint_E y^2 \, dV$ , where  $E$  is the solid hemisphere  $x^2 + y^2 + z^2 \leq 9$ ,  $y \geq 0$ .
25. Evaluate  $\iiint_E x e^{x^2 + y^2 + z^2} \, dV$ , where  $E$  is the portion of the unit ball  $x^2 + y^2 + z^2 \leq 1$  that lies in the first octant.
26. Evaluate  $\iiint_E xyz \, dV$ , where  $E$  lies between the spheres  $\rho = 2$  and  $\rho = 4$  and above the cone  $\phi = \pi/3$ .
27. Find the volume of the part of the ball  $\rho \leq a$  that lies between the cones  $\phi = \pi/6$  and  $\phi = \pi/3$ .
28. Find the average distance from a point in a ball of radius  $a$  to its center.
29. (a) Find the volume of the solid that lies above the cone  $\phi = \pi/3$  and below the sphere  $\rho = 4 \cos \phi$ .  
(b) Find the centroid of the solid in part (a).
30. Find the volume of the solid that lies within the sphere  $x^2 + y^2 + z^2 = 4$ , above the  $xy$ -plane, and below the cone  $z = \sqrt{x^2 + y^2}$ .
31. (a) Find the centroid of the solid in Example 4.  
(b) Find the moment of inertia about the  $z$ -axis for this solid.

32. Let  $H$  be a solid hemisphere of radius  $a$  whose density at any point is proportional to its distance from the center of the base.  
(a) Find the mass of  $H$ .  
(b) Find the center of mass of  $H$ .  
(c) Find the moment of inertia of  $H$  about its axis.
33. (a) Find the centroid of a solid homogeneous hemisphere of radius  $a$ .  
(b) Find the moment of inertia of the solid in part (a) about a diameter of its base.
34. Find the mass and center of mass of a solid hemisphere of radius  $a$  if the density at any point is proportional to its distance from the base.

**35–38** Use cylindrical or spherical coordinates, whichever seems more appropriate.

35. Find the volume and centroid of the solid  $E$  that lies above the cone  $z = \sqrt{x^2 + y^2}$  and below the sphere  $x^2 + y^2 + z^2 = 1$ .
36. Find the volume of the smaller wedge cut from a sphere of radius  $a$  by two planes that intersect along a diameter at an angle of  $\pi/6$ .
- CAS** 37. Evaluate  $\iiint_E z \, dV$ , where  $E$  lies above the paraboloid  $z = x^2 + y^2$  and below the plane  $z = 2y$ . Use either the Table of Integrals (on Reference Pages 6–10) or a computer algebra system to evaluate the integral.
- CAS** 38. (a) Find the volume enclosed by the torus  $\rho = \sin \phi$ .  
(b) Use a computer to draw the torus.


**39–41** Evaluate the integral by changing to spherical coordinates.

39. 
$$\int_0^1 \int_0^{\sqrt{1-x^2}} \int_{\sqrt{x^2+y^2}}^{\sqrt{2-x^2-y^2}} xy \, dz \, dy \, dx$$
40. 
$$\int_{-a}^a \int_{-\sqrt{a^2-y^2}}^{\sqrt{a^2-y^2}} \int_{-\sqrt{a^2-x^2-y^2}}^{\sqrt{a^2-x^2-y^2}} (x^2z + y^2z + z^3) \, dz \, dx \, dy$$
41. 
$$\int_{-2}^2 \int_{-\sqrt{4-x^2}}^{\sqrt{4-x^2}} \int_{2-\sqrt{4-x^2-y^2}}^{2+\sqrt{4-x^2-y^2}} (x^2 + y^2 + z^2)^{3/2} \, dz \, dy \, dx$$

42. A model for the density  $\delta$  of the earth's atmosphere near its surface is

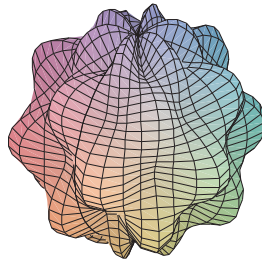
$$\delta = 619.09 - 0.000097\rho$$

where  $\rho$  (the distance from the center of the earth) is measured in meters and  $\delta$  is measured in kilograms per cubic meter. If we take the surface of the earth to be a sphere with radius 6370 km, then this model is a reasonable one for  $6.370 \times 10^6 \leq \rho \leq 6.375 \times 10^6$ . Use this model to estimate the mass of the atmosphere between the ground and an altitude of 5 km.

-  43. Use a graphing device to draw a silo consisting of a cylinder with radius 3 and height 10 surmounted by a hemisphere.

44. The latitude and longitude of a point  $P$  in the Northern Hemisphere are related to spherical coordinates  $\rho$ ,  $\theta$ ,  $\phi$  as follows. We take the origin to be the center of the earth and the positive  $z$ -axis to pass through the North Pole. The positive  $x$ -axis passes through the point where the prime meridian (the meridian through Greenwich, England) intersects the equator. Then the latitude of  $P$  is  $\alpha = 90^\circ - \phi^\circ$  and the longitude is  $\beta = 360^\circ - \theta^\circ$ . Find the great-circle distance from Los Angeles (lat.  $34.06^\circ$  N, long.  $118.25^\circ$  W) to Montréal (lat.  $45.50^\circ$  N, long.  $73.60^\circ$  W). Take the radius of the earth to be 3960 mi. (A *great circle* is the circle of intersection of a sphere and a plane through the center of the sphere.)

- CAS** 45. The surfaces  $\rho = 1 + \frac{1}{5} \sin m\theta \sin n\phi$  have been used as models for tumors. The “bumpy sphere” with  $m = 6$  and  $n = 5$  is shown. Use a computer algebra system to find the volume it encloses.



46. Show that

$$\int_{-\infty}^{\infty} \int_{-\infty}^{\infty} \int_{-\infty}^{\infty} \sqrt{x^2 + y^2 + z^2} e^{-(x^2+y^2+z^2)} dx dy dz = 2\pi$$

(The improper triple integral is defined as the limit of a triple integral over a solid sphere as the radius of the sphere increases indefinitely.)

47. (a) Use cylindrical coordinates to show that the volume of the solid bounded above by the sphere  $r^2 + z^2 = a^2$  and below by the cone  $z = r \cot \phi_0$  (or  $\phi = \phi_0$ ), where  $0 < \phi_0 < \pi/2$ , is

$$V = \frac{2\pi a^3}{3} (1 - \cos \phi_0)$$

- (b) Deduce that the volume of the spherical wedge given by  $\rho_1 \leq \rho \leq \rho_2$ ,  $\theta_1 \leq \theta \leq \theta_2$ ,  $\phi_1 \leq \phi \leq \phi_2$  is

$$\Delta V = \frac{\rho_2^3 - \rho_1^3}{3} (\cos \phi_1 - \cos \phi_2)(\theta_2 - \theta_1)$$

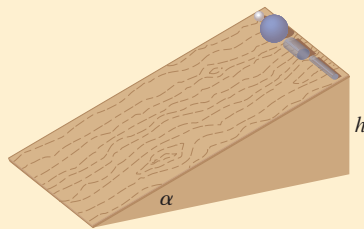
- (c) Use the Mean Value Theorem to show that the volume in part (b) can be written as

$$\Delta V = \bar{\rho}^2 \sin \bar{\phi} \Delta \rho \Delta \theta \Delta \phi$$

where  $\bar{\rho}$  lies between  $\rho_1$  and  $\rho_2$ ,  $\bar{\phi}$  lies between  $\phi_1$  and  $\phi_2$ ,  $\Delta \rho = \rho_2 - \rho_1$ ,  $\Delta \theta = \theta_2 - \theta_1$ , and  $\Delta \phi = \phi_2 - \phi_1$ .

## APPLIED PROJECT

## ROLLER DERBY



Suppose that a solid ball (a marble), a hollow ball (a squash ball), a solid cylinder (a steel bar), and a hollow cylinder (a lead pipe) roll down a slope. Which of these objects reaches the bottom first? (Make a guess before proceeding.)

To answer this question, we consider a ball or cylinder with mass  $m$ , radius  $r$ , and moment of inertia  $I$  (about the axis of rotation). If the vertical drop is  $h$ , then the potential energy at the top is  $mgh$ . Suppose the object reaches the bottom with velocity  $v$  and angular velocity  $\omega$ , so  $v = \omega r$ . The kinetic energy at the bottom consists of two parts:  $\frac{1}{2}mv^2$  from translation (moving down the slope) and  $\frac{1}{2}I\omega^2$  from rotation. If we assume that energy loss from rolling friction is negligible, then conservation of energy gives

$$mgh = \frac{1}{2}mv^2 + \frac{1}{2}I\omega^2$$

1. Show that

$$v^2 = \frac{2gh}{1 + I^*} \quad \text{where } I^* = \frac{I}{mr^2}$$

2. If  $y(t)$  is the vertical distance traveled at time  $t$ , then the same reasoning as used in Problem 1 shows that  $v^2 = 2gy/(1 + I^*)$  at any time  $t$ . Use this result to show that  $y$  satisfies the differential equation

$$\frac{dy}{dt} = \sqrt{\frac{2g}{1 + I^*}} (\sin \alpha) \sqrt{y}$$

where  $\alpha$  is the angle of inclination of the plane.

3. By solving the differential equation in Problem 2, show that the total travel time is

$$T = \sqrt{\frac{2h(1 + I^*)}{g \sin^2 \alpha}}$$

This shows that the object with the smallest value of  $I^*$  wins the race.

4. Show that  $I^* = \frac{1}{2}$  for a solid cylinder and  $I^* = 1$  for a hollow cylinder.
5. Calculate  $I^*$  for a partly hollow ball with inner radius  $a$  and outer radius  $r$ . Express your answer in terms of  $b = a/r$ . What happens as  $a \rightarrow 0$  and as  $a \rightarrow r$ ?
6. Show that  $I^* = \frac{2}{5}$  for a solid ball and  $I^* = \frac{2}{3}$  for a hollow ball. Thus the objects finish in the following order: solid ball, solid cylinder, hollow ball, hollow cylinder.

## 15.10 Change of Variables in Multiple Integrals

In one-dimensional calculus we often use a change of variable (a substitution) to simplify an integral. By reversing the roles of  $x$  and  $u$ , we can write the Substitution Rule (5.5.6) as

$$\boxed{1} \quad \int_a^b f(x) dx = \int_c^d f(g(u)) g'(u) du$$

where  $x = g(u)$  and  $a = g(c)$ ,  $b = g(d)$ . Another way of writing Formula 1 is as follows:

$$\boxed{2} \quad \int_a^b f(x) dx = \int_c^d f(x(u)) \frac{dx}{du} du$$

A change of variables can also be useful in double integrals. We have already seen one example of this: conversion to polar coordinates. The new variables  $r$  and  $\theta$  are related to the old variables  $x$  and  $y$  by the equations

$$x = r \cos \theta \quad y = r \sin \theta$$

and the change of variables formula (15.4.2) can be written as

$$\iint_R f(x, y) dA = \iint_S f(r \cos \theta, r \sin \theta) r dr d\theta$$

where  $S$  is the region in the  $r\theta$ -plane that corresponds to the region  $R$  in the  $xy$ -plane.

More generally, we consider a change of variables that is given by a **transformation**  $T$  from the  $uv$ -plane to the  $xy$ -plane:

$$T(u, v) = (x, y)$$

where  $x$  and  $y$  are related to  $u$  and  $v$  by the equations

$$\boxed{3} \quad x = g(u, v) \quad y = h(u, v)$$

or, as we sometimes write,

$$x = x(u, v) \quad y = y(u, v)$$

We usually assume that  $T$  is a  $C^1$  **transformation**, which means that  $g$  and  $h$  have continuous first-order partial derivatives.

A transformation  $T$  is really just a function whose domain and range are both subsets of  $\mathbb{R}^2$ . If  $T(u_1, v_1) = (x_1, y_1)$ , then the point  $(x_1, y_1)$  is called the **image** of the point  $(u_1, v_1)$ . If no two points have the same image,  $T$  is called **one-to-one**. Figure 1 shows the effect of a transformation  $T$  on a region  $S$  in the  $uv$ -plane.  $T$  transforms  $S$  into a region  $R$  in the  $xy$ -plane called the **image of  $S$** , consisting of the images of all points in  $S$ .

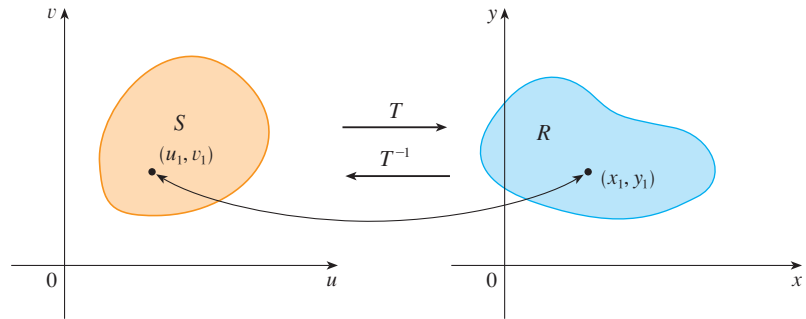


FIGURE 1

If  $T$  is a one-to-one transformation, then it has an **inverse transformation**  $T^{-1}$  from the  $xy$ -plane to the  $uv$ -plane and it may be possible to solve Equations 3 for  $u$  and  $v$  in terms of  $x$  and  $y$ :

$$u = G(x, y) \quad v = H(x, y)$$

**V EXAMPLE 1** A transformation is defined by the equations

$$x = u^2 - v^2 \quad y = 2uv$$

Find the image of the square  $S = \{(u, v) \mid 0 \leq u \leq 1, 0 \leq v \leq 1\}$ .

**SOLUTION** The transformation maps the boundary of  $S$  into the boundary of the image. So we begin by finding the images of the sides of  $S$ . The first side,  $S_1$ , is given by  $v = 0$  ( $0 \leq u \leq 1$ ). (See Figure 2.) From the given equations we have  $x = u^2$ ,  $y = 0$ , and so  $0 \leq x \leq 1$ . Thus  $S_1$  is mapped into the line segment from  $(0, 0)$  to  $(1, 0)$  in the  $xy$ -plane. The second side,  $S_2$ , is  $u = 1$  ( $0 \leq v \leq 1$ ) and, putting  $u = 1$  in the given equations, we get

$$x = 1 - v^2 \quad y = 2v$$

Eliminating  $v$ , we obtain

$$\boxed{4} \quad x = 1 - \frac{y^2}{4} \quad 0 \leq x \leq 1$$

which is part of a parabola. Similarly,  $S_3$  is given by  $v = 1$  ( $0 \leq u \leq 1$ ), whose image is the parabolic arc

$$\boxed{5} \quad x = \frac{y^2}{4} - 1 \quad -1 \leq x \leq 0$$

Finally,  $S_4$  is given by  $u = 0$  ( $0 \leq v \leq 1$ ) whose image is  $x = -v^2$ ,  $y = 0$ , that is,  $-1 \leq x \leq 0$ . (Notice that as we move around the square in the counterclockwise direction, we also move around the parabolic region in the counterclockwise direction.) The image of  $S$  is the region  $R$  (shown in Figure 2) bounded by the  $x$ -axis and the parabolas given by Equations 4 and 5.

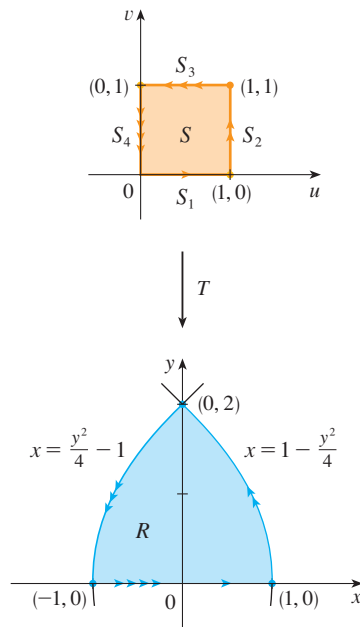


FIGURE 2

Now let's see how a change of variables affects a double integral. We start with a small rectangle  $S$  in the  $uv$ -plane whose lower left corner is the point  $(u_0, v_0)$  and whose dimensions are  $\Delta u$  and  $\Delta v$ . (See Figure 3.)

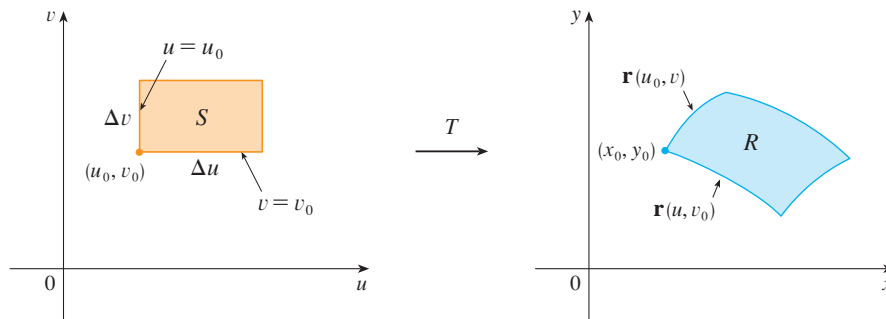


FIGURE 3

The image of  $S$  is a region  $R$  in the  $xy$ -plane, one of whose boundary points is  $(x_0, y_0) = T(u_0, v_0)$ . The vector

$$\mathbf{r}(u, v) = g(u, v)\mathbf{i} + h(u, v)\mathbf{j}$$

is the position vector of the image of the point  $(u, v)$ . The equation of the lower side of  $S$  is  $v = v_0$ , whose image curve is given by the vector function  $\mathbf{r}(u, v_0)$ . The tangent vector at  $(x_0, y_0)$  to this image curve is

$$\mathbf{r}_u = g_u(u_0, v_0)\mathbf{i} + h_u(u_0, v_0)\mathbf{j} = \frac{\partial x}{\partial u}\mathbf{i} + \frac{\partial y}{\partial u}\mathbf{j}$$

Similarly, the tangent vector at  $(x_0, y_0)$  to the image curve of the left side of  $S$  (namely,  $u = u_0$ ) is

$$\mathbf{r}_v = g_v(u_0, v_0)\mathbf{i} + h_v(u_0, v_0)\mathbf{j} = \frac{\partial x}{\partial v}\mathbf{i} + \frac{\partial y}{\partial v}\mathbf{j}$$

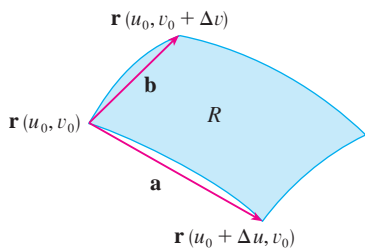


FIGURE 4

We can approximate the image region  $R = T(S)$  by a parallelogram determined by the secant vectors

$$\mathbf{a} = \mathbf{r}(u_0 + \Delta u, v_0) - \mathbf{r}(u_0, v_0) \quad \mathbf{b} = \mathbf{r}(u_0, v_0 + \Delta v) - \mathbf{r}(u_0, v_0)$$

shown in Figure 4. But

$$\mathbf{r}_u = \lim_{\Delta u \rightarrow 0} \frac{\mathbf{r}(u_0 + \Delta u, v_0) - \mathbf{r}(u_0, v_0)}{\Delta u}$$

and so

$$\mathbf{r}(u_0 + \Delta u, v_0) - \mathbf{r}(u_0, v_0) \approx \Delta u \mathbf{r}_u$$

Similarly

$$\mathbf{r}(u_0, v_0 + \Delta v) - \mathbf{r}(u_0, v_0) \approx \Delta v \mathbf{r}_v$$

This means that we can approximate  $R$  by a parallelogram determined by the vectors  $\Delta u \mathbf{r}_u$  and  $\Delta v \mathbf{r}_v$ . (See Figure 5.) Therefore we can approximate the area of  $R$  by the area of this parallelogram, which, from Section 12.4, is

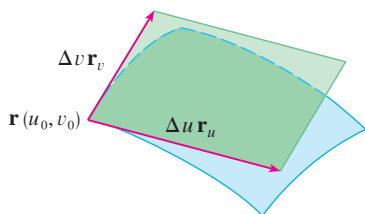


FIGURE 5

$$\boxed{6} \quad |(\Delta u \mathbf{r}_u) \times (\Delta v \mathbf{r}_v)| = |\mathbf{r}_u \times \mathbf{r}_v| \Delta u \Delta v$$

Computing the cross product, we obtain

$$\mathbf{r}_u \times \mathbf{r}_v = \begin{vmatrix} \mathbf{i} & \mathbf{j} & \mathbf{k} \\ \frac{\partial x}{\partial u} & \frac{\partial y}{\partial u} & 0 \\ \frac{\partial x}{\partial v} & \frac{\partial y}{\partial v} & 0 \end{vmatrix} = \begin{vmatrix} \frac{\partial x}{\partial u} & \frac{\partial y}{\partial u} \\ \frac{\partial x}{\partial v} & \frac{\partial y}{\partial v} \end{vmatrix} \mathbf{k} = \begin{vmatrix} \frac{\partial x}{\partial u} & \frac{\partial x}{\partial v} \\ \frac{\partial y}{\partial u} & \frac{\partial y}{\partial v} \end{vmatrix} \mathbf{k}$$

The determinant that arises in this calculation is called the *Jacobian* of the transformation and is given a special notation.

The Jacobian is named after the German mathematician Carl Gustav Jacob Jacobi (1804–1851). Although the French mathematician Cauchy first used these special determinants involving partial derivatives, Jacobi developed them into a method for evaluating multiple integrals.

**7 Definition** The **Jacobian** of the transformation  $T$  given by  $x = g(u, v)$  and  $y = h(u, v)$  is

$$\frac{\partial(x, y)}{\partial(u, v)} = \begin{vmatrix} \frac{\partial x}{\partial u} & \frac{\partial x}{\partial v} \\ \frac{\partial y}{\partial u} & \frac{\partial y}{\partial v} \end{vmatrix} = \frac{\partial x}{\partial u} \frac{\partial y}{\partial v} - \frac{\partial x}{\partial v} \frac{\partial y}{\partial u}$$

With this notation we can use Equation 6 to give an approximation to the area  $\Delta A$  of  $R$ :

**8** 
$$\Delta A \approx \left| \frac{\partial(x, y)}{\partial(u, v)} \right| \Delta u \Delta v$$

where the Jacobian is evaluated at  $(u_0, v_0)$ .

Next we divide a region  $S$  in the  $uv$ -plane into rectangles  $S_{ij}$  and call their images in the  $xy$ -plane  $R_{ij}$ . (See Figure 6.)

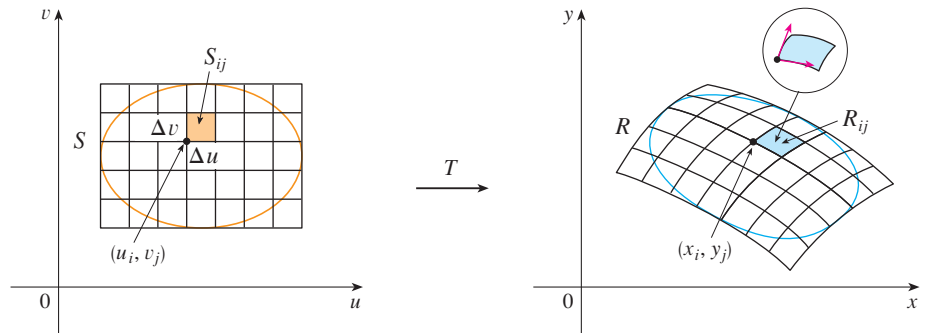


FIGURE 6

Applying the approximation **8** to each  $R_{ij}$ , we approximate the double integral of  $f$  over  $R$  as follows:

$$\begin{aligned} \iint_R f(x, y) \, dA &\approx \sum_{i=1}^m \sum_{j=1}^n f(x_i, y_j) \Delta A \\ &\approx \sum_{i=1}^m \sum_{j=1}^n f(g(u_i, v_j), h(u_i, v_j)) \left| \frac{\partial(x, y)}{\partial(u, v)} \right| \Delta u \Delta v \end{aligned}$$

where the Jacobian is evaluated at  $(u_i, v_j)$ . Notice that this double sum is a Riemann sum for the integral

$$\iint_S f(g(u, v), h(u, v)) \left| \frac{\partial(x, y)}{\partial(u, v)} \right| du dv$$

The foregoing argument suggests that the following theorem is true. (A full proof is given in books on advanced calculus.)

**9 Change of Variables in a Double Integral** Suppose that  $T$  is a  $C^1$  transformation whose Jacobian is nonzero and that maps a region  $S$  in the  $uv$ -plane onto a region  $R$  in the  $xy$ -plane. Suppose that  $f$  is continuous on  $R$  and that  $R$  and  $S$  are type I or type II plane regions. Suppose also that  $T$  is one-to-one, except perhaps on the boundary of  $S$ . Then

$$\iint_R f(x, y) dA = \iint_S f(x(u, v), y(u, v)) \left| \frac{\partial(x, y)}{\partial(u, v)} \right| du dv$$

Theorem 9 says that we change from an integral in  $x$  and  $y$  to an integral in  $u$  and  $v$  by expressing  $x$  and  $y$  in terms of  $u$  and  $v$  and writing

$$dA = \left| \frac{\partial(x, y)}{\partial(u, v)} \right| du dv$$

Notice the similarity between Theorem 9 and the one-dimensional formula in Equation 2. Instead of the derivative  $dx/du$ , we have the absolute value of the Jacobian, that is,  $|\partial(x, y)/\partial(u, v)|$ .

As a first illustration of Theorem 9, we show that the formula for integration in polar coordinates is just a special case. Here the transformation  $T$  from the  $r\theta$ -plane to the  $xy$ -plane is given by

$$x = g(r, \theta) = r \cos \theta \quad y = h(r, \theta) = r \sin \theta$$

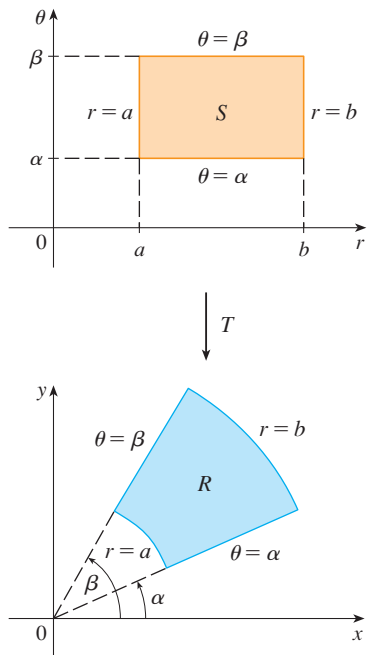
and the geometry of the transformation is shown in Figure 7.  $T$  maps an ordinary rectangle in the  $r\theta$ -plane to a polar rectangle in the  $xy$ -plane. The Jacobian of  $T$  is

$$\frac{\partial(x, y)}{\partial(r, \theta)} = \begin{vmatrix} \frac{\partial x}{\partial r} & \frac{\partial x}{\partial \theta} \\ \frac{\partial y}{\partial r} & \frac{\partial y}{\partial \theta} \end{vmatrix} = \begin{vmatrix} \cos \theta & -r \sin \theta \\ \sin \theta & r \cos \theta \end{vmatrix} = r \cos^2 \theta + r \sin^2 \theta = r > 0$$

Thus Theorem 9 gives

$$\begin{aligned} \iint_R f(x, y) dx dy &= \iint_S f(r \cos \theta, r \sin \theta) \left| \frac{\partial(x, y)}{\partial(r, \theta)} \right| dr d\theta \\ &= \int_{\alpha}^{\beta} \int_a^b f(r \cos \theta, r \sin \theta) r dr d\theta \end{aligned}$$

which is the same as Formula 15.4.2.



**FIGURE 7**  
The polar coordinate transformation



**EXAMPLE 2** Use the change of variables  $x = u^2 - v^2$ ,  $y = 2uv$  to evaluate the integral  $\iint_R y \, dA$ , where  $R$  is the region bounded by the  $x$ -axis and the parabolas  $y^2 = 4 - 4x$  and  $y^2 = 4 + 4x$ ,  $y \geq 0$ .

**SOLUTION** The region  $R$  is pictured in Figure 2 (on page 1041). In Example 1 we discovered that  $T(S) = R$ , where  $S$  is the square  $[0, 1] \times [0, 1]$ . Indeed, the reason for making the change of variables to evaluate the integral is that  $S$  is a much simpler region than  $R$ . First we need to compute the Jacobian:

$$\frac{\partial(x, y)}{\partial(u, v)} = \begin{vmatrix} \frac{\partial x}{\partial u} & \frac{\partial x}{\partial v} \\ \frac{\partial y}{\partial u} & \frac{\partial y}{\partial v} \end{vmatrix} = \begin{vmatrix} 2u & -2v \\ 2v & 2u \end{vmatrix} = 4u^2 + 4v^2 > 0$$

Therefore, by Theorem 9,

$$\begin{aligned} \iint_R y \, dA &= \iint_S 2uv \left| \frac{\partial(x, y)}{\partial(u, v)} \right| dA = \int_0^1 \int_0^1 (2uv)4(u^2 + v^2) \, du \, dv \\ &= 8 \int_0^1 \int_0^1 (u^3v + uv^3) \, du \, dv = 8 \int_0^1 \left[ \frac{1}{4}u^4v + \frac{1}{2}u^2v^3 \right]_{u=0}^{u=1} dv \\ &= \int_0^1 (2v + 4v^3) \, dv = \left[ v^2 + v^4 \right]_0^1 = 2 \end{aligned}$$

**NOTE** Example 2 was not a very difficult problem to solve because we were given a suitable change of variables. If we are not supplied with a transformation, then the first step is to think of an appropriate change of variables. If  $f(x, y)$  is difficult to integrate, then the form of  $f(x, y)$  may suggest a transformation. If the region of integration  $R$  is awkward, then the transformation should be chosen so that the corresponding region  $S$  in the  $uv$ -plane has a convenient description.

**EXAMPLE 3** Evaluate the integral  $\iint_R e^{(x+y)/(x-y)} \, dA$ , where  $R$  is the trapezoidal region with vertices  $(1, 0)$ ,  $(2, 0)$ ,  $(0, -2)$ , and  $(-1, -1)$ .

**SOLUTION** Since it isn't easy to integrate  $e^{(x+y)/(x-y)}$ , we make a change of variables suggested by the form of this function:

$$\boxed{10} \quad u = x + y \quad v = x - y$$

These equations define a transformation  $T^{-1}$  from the  $xy$ -plane to the  $uv$ -plane. Theorem 9 talks about a transformation  $T$  from the  $uv$ -plane to the  $xy$ -plane. It is obtained by solving Equations 10 for  $x$  and  $y$ :

$$\boxed{11} \quad x = \frac{1}{2}(u + v) \quad y = \frac{1}{2}(u - v)$$

The Jacobian of  $T$  is

$$\frac{\partial(x, y)}{\partial(u, v)} = \begin{vmatrix} \frac{\partial x}{\partial u} & \frac{\partial x}{\partial v} \\ \frac{\partial y}{\partial u} & \frac{\partial y}{\partial v} \end{vmatrix} = \begin{vmatrix} \frac{1}{2} & \frac{1}{2} \\ \frac{1}{2} & -\frac{1}{2} \end{vmatrix} = -\frac{1}{2}$$

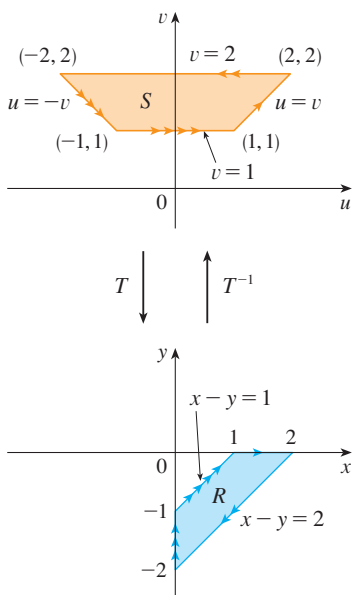


FIGURE 8

To find the region  $S$  in the  $uv$ -plane corresponding to  $R$ , we note that the sides of  $R$  lie on the lines

$$y = 0 \quad x - y = 2 \quad x = 0 \quad x - y = 1$$

and, from either Equations 10 or Equations 11, the image lines in the  $uv$ -plane are

$$u = v \quad v = 2 \quad u = -v \quad v = 1$$

Thus the region  $S$  is the trapezoidal region with vertices  $(1, 1)$ ,  $(2, 2)$ ,  $(-2, 2)$ , and  $(-1, 1)$  shown in Figure 8. Since

$$S = \{(u, v) \mid 1 \leq v \leq 2, -v \leq u \leq v\}$$

Theorem 9 gives

$$\begin{aligned} \iint_R e^{(x+y)/(x-y)} dA &= \iint_S e^{u/v} \left| \frac{\partial(x, y)}{\partial(u, v)} \right| du dv \\ &= \int_1^2 \int_{-v}^v e^{u/v} \left(\frac{1}{2}\right) du dv = \frac{1}{2} \int_1^2 [ve^{u/v}]_{u=-v}^{u=v} dv \\ &= \frac{1}{2} \int_1^2 (e - e^{-1})v dv = \frac{3}{4}(e - e^{-1}) \end{aligned}$$

### Triple Integrals

There is a similar change of variables formula for triple integrals. Let  $T$  be a transformation that maps a region  $S$  in  $uvw$ -space onto a region  $R$  in  $xyz$ -space by means of the equations

$$x = g(u, v, w) \quad y = h(u, v, w) \quad z = k(u, v, w)$$

The **Jacobian** of  $T$  is the following  $3 \times 3$  determinant:

$$\frac{\partial(x, y, z)}{\partial(u, v, w)} = \begin{vmatrix} \frac{\partial x}{\partial u} & \frac{\partial x}{\partial v} & \frac{\partial x}{\partial w} \\ \frac{\partial y}{\partial u} & \frac{\partial y}{\partial v} & \frac{\partial y}{\partial w} \\ \frac{\partial z}{\partial u} & \frac{\partial z}{\partial v} & \frac{\partial z}{\partial w} \end{vmatrix}$$

Under hypotheses similar to those in Theorem 9, we have the following formula for triple integrals:

$$\iiint_R f(x, y, z) dV = \iiint_S f(x(u, v, w), y(u, v, w), z(u, v, w)) \left| \frac{\partial(x, y, z)}{\partial(u, v, w)} \right| du dv dw$$

**EXAMPLE 4** Use Formula 13 to derive the formula for triple integration in spherical coordinates.

**SOLUTION** Here the change of variables is given by

$$x = \rho \sin \phi \cos \theta \quad y = \rho \sin \phi \sin \theta \quad z = \rho \cos \phi$$

We compute the Jacobian as follows:

$$\begin{aligned} \frac{\partial(x, y, z)}{\partial(\rho, \theta, \phi)} &= \begin{vmatrix} \sin \phi \cos \theta & -\rho \sin \phi \sin \theta & \rho \cos \phi \cos \theta \\ \sin \phi \sin \theta & \rho \sin \phi \cos \theta & \rho \cos \phi \sin \theta \\ \cos \phi & 0 & -\rho \sin \phi \end{vmatrix} \\ &= \cos \phi \begin{vmatrix} -\rho \sin \phi \sin \theta & \rho \cos \phi \cos \theta \\ \rho \sin \phi \cos \theta & \rho \cos \phi \sin \theta \end{vmatrix} - \rho \sin \phi \begin{vmatrix} \sin \phi \cos \theta & -\rho \sin \phi \sin \theta \\ \sin \phi \sin \theta & \rho \sin \phi \cos \theta \end{vmatrix} \\ &= \cos \phi (-\rho^2 \sin \phi \cos \phi \sin^2 \theta - \rho^2 \sin \phi \cos \phi \cos^2 \theta) \\ &\quad - \rho \sin \phi (\rho \sin^2 \phi \cos^2 \theta + \rho \sin^2 \phi \sin^2 \theta) \\ &= -\rho^2 \sin \phi \cos^2 \phi - \rho^2 \sin \phi \sin^2 \phi = -\rho^2 \sin \phi \end{aligned}$$

Since  $0 \leq \phi \leq \pi$ , we have  $\sin \phi \geq 0$ . Therefore

$$\left| \frac{\partial(x, y, z)}{\partial(\rho, \theta, \phi)} \right| = |-\rho^2 \sin \phi| = \rho^2 \sin \phi$$

and Formula 13 gives

$$\iiint_R f(x, y, z) dV = \iiint_S f(\rho \sin \phi \cos \theta, \rho \sin \phi \sin \theta, \rho \cos \phi) \rho^2 \sin \phi d\rho d\theta d\phi$$

which is equivalent to Formula 15.9.3.

## 15.10 Exercises

**1–6** Find the Jacobian of the transformation.

1.  $x = 5u - v, \quad y = u + 3v$
2.  $x = uv, \quad y = u/v$
3.  $x = e^{-t} \sin \theta, \quad y = e^r \cos \theta$
4.  $x = e^{s+t}, \quad y = e^{s-t}$
5.  $x = u/v, \quad y = v/w, \quad z = w/u$
6.  $x = v + w^2, \quad y = w + u^2, \quad z = u + v^2$

**7–10** Find the image of the set  $S$  under the given transformation.


7.  $S = \{(u, v) \mid 0 \leq u \leq 3, 0 \leq v \leq 2\};$   
 $x = 2u + 3v, y = u - v$
8.  $S$  is the square bounded by the lines  $u = 0, u = 1, v = 0,$   
 $v = 1; \quad x = v, y = u(1 + v^2)$
9.  $S$  is the triangular region with vertices  $(0, 0), (1, 1), (0, 1);$   
 $x = u^2, y = v$
10.  $S$  is the disk given by  $u^2 + v^2 \leq 1; \quad x = au, y = bv$

**11–14** A region  $R$  in the  $xy$ -plane is given. Find equations for a transformation  $T$  that maps a rectangular region  $S$  in the  $uv$ -plane onto  $R$ , where the sides of  $S$  are parallel to the  $u$ - and  $v$ - axes.

11.  $R$  is bounded by  $y = 2x - 1, y = 2x + 1, y = 1 - x,$   
 $y = 3 - x$
12.  $R$  is the parallelogram with vertices  $(0, 0), (4, 3), (2, 4), (-2, 1)$
13.  $R$  lies between the circles  $x^2 + y^2 = 1$  and  $x^2 + y^2 = 2$  in the first quadrant
14.  $R$  is bounded by the hyperbolas  $y = 1/x, y = 4/x$  and the lines  $y = x, y = 4x$  in the first quadrant

**15–20** Use the given transformation to evaluate the integral.

15.  $\iint_R (x - 3y) dA$ , where  $R$  is the triangular region with vertices  $(0, 0), (2, 1),$  and  $(1, 2); \quad x = 2u + v, y = u + 2v$
16.  $\iint_R (4x + 8y) dA$ , where  $R$  is the parallelogram with vertices  $(-1, 3), (1, -3), (3, -1),$  and  $(1, 5);$   
 $x = \frac{1}{4}(u + v), y = \frac{1}{4}(v - 3u)$
17.  $\iint_R x^2 dA$ , where  $R$  is the region bounded by the ellipse  $9x^2 + 4y^2 = 36; \quad x = 2u, y = 3v$

18.  $\iint_R (x^2 - xy + y^2) dA$ , where  $R$  is the region bounded by the ellipse  $x^2 - xy + y^2 = 2$ ;  
 $x = \sqrt{2}u - \sqrt{2/3}v$ ,  $y = \sqrt{2}u + \sqrt{2/3}v$
19.  $\iint_R xy dA$ , where  $R$  is the region in the first quadrant bounded by the lines  $y = x$  and  $y = 3x$  and the hyperbolas  $xy = 1$ ,  $xy = 3$ ;  $x = u/v$ ,  $y = v$
-  20.  $\iint_R y^2 dA$ , where  $R$  is the region bounded by the curves  $xy = 1$ ,  $xy = 2$ ,  $xy^2 = 1$ ,  $xy^2 = 2$ ;  $u = xy$ ,  $v = xy^2$ . Illustrate by using a graphing calculator or computer to draw  $R$ .
- 
21. (a) Evaluate  $\iiint_E dV$ , where  $E$  is the solid enclosed by the ellipsoid  $x^2/a^2 + y^2/b^2 + z^2/c^2 = 1$ . Use the transformation  $x = au$ ,  $y = bv$ ,  $z = cw$ .  
 (b) The earth is not a perfect sphere; rotation has resulted in flattening at the poles. So the shape can be approximated by an ellipsoid with  $a = b = 6378$  km and  $c = 6356$  km. Use part (a) to estimate the volume of the earth.  
 (c) If the solid of part (a) has constant density  $k$ , find its moment of inertia about the  $z$ -axis.
22. An important problem in thermodynamics is to find the work done by an ideal Carnot engine. A cycle consists of alternating expansion and compression of gas in a piston. The work done by the engine is equal to the area of the region  $R$  enclosed by two isothermal curves  $xy = a$ ,  $xy = b$  and two adiabatic curves

$xy^{1.4} = c$ ,  $xy^{1.4} = d$ , where  $0 < a < b$  and  $0 < c < d$ . Compute the work done by determining the area of  $R$ .

**23–27** Evaluate the integral by making an appropriate change of variables.

23.  $\iint_R \frac{x - 2y}{3x - y} dA$ , where  $R$  is the parallelogram enclosed by the lines  $x - 2y = 0$ ,  $x - 2y = 4$ ,  $3x - y = 1$ , and  $3x - y = 8$
24.  $\iint_R (x + y)e^{x^2 - y^2} dA$ , where  $R$  is the rectangle enclosed by the lines  $x - y = 0$ ,  $x - y = 2$ ,  $x + y = 0$ , and  $x + y = 3$
25.  $\iint_R \cos\left(\frac{y - x}{y + x}\right) dA$ , where  $R$  is the trapezoidal region with vertices  $(1, 0)$ ,  $(2, 0)$ ,  $(0, 2)$ , and  $(0, 1)$
26.  $\iint_R \sin(9x^2 + 4y^2) dA$ , where  $R$  is the region in the first quadrant bounded by the ellipse  $9x^2 + 4y^2 = 1$
27.  $\iint_R e^{x+y} dA$ , where  $R$  is given by the inequality  $|x| + |y| \leq 1$
- 
28. Let  $f$  be continuous on  $[0, 1]$  and let  $R$  be the triangular region with vertices  $(0, 0)$ ,  $(1, 0)$ , and  $(0, 1)$ . Show that

$$\iint_R f(x + y) dA = \int_0^1 uf(u) du$$

## 15 Review

## Concept Check

- Suppose  $f$  is a continuous function defined on a rectangle  $R = [a, b] \times [c, d]$ .
  - Write an expression for a double Riemann sum of  $f$ . If  $f(x, y) \geq 0$ , what does the sum represent?
  - Write the definition of  $\iint_R f(x, y) dA$  as a limit.
  - What is the geometric interpretation of  $\iint_R f(x, y) dA$  if  $f(x, y) \geq 0$ ? What if  $f$  takes on both positive and negative values?
  - How do you evaluate  $\iint_R f(x, y) dA$ ?
  - What does the Midpoint Rule for double integrals say?
  - Write an expression for the average value of  $f$ .
- How do you define  $\iint_D f(x, y) dA$  if  $D$  is a bounded region that is not a rectangle?
  - What is a type I region? How do you evaluate  $\iint_D f(x, y) dA$  if  $D$  is a type I region?
  - What is a type II region? How do you evaluate  $\iint_D f(x, y) dA$  if  $D$  is a type II region?
  - What properties do double integrals have?
- How do you change from rectangular coordinates to polar coordinates in a double integral? Why would you want to make the change?
- If a lamina occupies a plane region  $D$  and has density function  $\rho(x, y)$ , write expressions for each of the following in terms of double integrals.
  - The mass
  - The moments about the axes
  - The center of mass
  - The moments of inertia about the axes and the origin
- Let  $f$  be a joint density function of a pair of continuous random variables  $X$  and  $Y$ .
  - Write a double integral for the probability that  $X$  lies between  $a$  and  $b$  and  $Y$  lies between  $c$  and  $d$ .
    - What properties does  $f$  possess?
    - What are the expected values of  $X$  and  $Y$ ?
- Write an expression for the area of a surface with equation  $z = f(x, y)$ ,  $(x, y) \in D$ .
- Write the definition of the triple integral of  $f$  over a rectangular box  $B$ .
  - How do you evaluate  $\iiint_B f(x, y, z) dV$ ?
  - How do you define  $\iiint_E f(x, y, z) dV$  if  $E$  is a bounded solid region that is not a box?
  - What is a type 1 solid region? How do you evaluate  $\iiint_E f(x, y, z) dV$  if  $E$  is such a region?
  - What is a type 2 solid region? How do you evaluate  $\iiint_E f(x, y, z) dV$  if  $E$  is such a region?
  - What is a type 3 solid region? How do you evaluate  $\iiint_E f(x, y, z) dV$  if  $E$  is such a region?
- Suppose a solid object occupies the region  $E$  and has density function  $\rho(x, y, z)$ . Write expressions for each of the following.
  - The mass
  - The moments about the coordinate planes
  - The coordinates of the center of mass
  - The moments of inertia about the axes
- How do you change from rectangular coordinates to cylindrical coordinates in a triple integral?
  - How do you change from rectangular coordinates to spherical coordinates in a triple integral?
  - In what situations would you change to cylindrical or spherical coordinates?
- If a transformation  $T$  is given by  $x = g(u, v)$ ,  $y = h(u, v)$ , what is the Jacobian of  $T$ ?
  - How do you change variables in a double integral?
  - How do you change variables in a triple integral?

## True-False Quiz

Determine whether the statement is true or false. If it is true, explain why. If it is false, explain why or give an example that disproves the statement.

- $\int_{-1}^2 \int_0^6 x^2 \sin(x - y) dx dy = \int_0^6 \int_{-1}^2 x^2 \sin(x - y) dy dx$
- $\int_0^1 \int_0^x \sqrt{x + y^2} dy dx = \int_0^x \int_0^1 \sqrt{x + y^2} dx dy$
- $\int_1^2 \int_3^4 x^2 e^y dy dx = \int_1^2 x^2 dx \int_3^4 e^y dy$
- $\int_{-1}^1 \int_0^1 e^{x^2+y^2} \sin y dx dy = 0$
- If  $f$  is continuous on  $[0, 1]$ , then

$$\int_0^1 \int_0^1 f(x)f(y) dy dx = \left[ \int_0^1 f(x) dx \right]^2$$

$$6. \int_1^4 \int_0^1 (x^2 + \sqrt{y}) \sin(x^2 y^2) dx dy \leq 9$$

- If  $D$  is the disk given by  $x^2 + y^2 \leq 4$ , then

$$\iint_D \sqrt{4 - x^2 - y^2} dA = \frac{16}{3} \pi$$

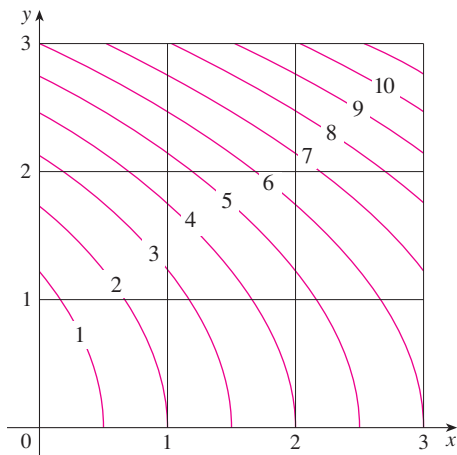
- The integral  $\iiint_E kr^3 dz dr d\theta$  represents the moment of inertia about the  $z$ -axis of a solid  $E$  with constant density  $k$ .
- The integral

$$\int_0^{2\pi} \int_0^2 \int_r^2 dz dr d\theta$$

represents the volume enclosed by the cone  $z = \sqrt{x^2 + y^2}$  and the plane  $z = 2$ .

## Exercises

1. A contour map is shown for a function  $f$  on the square  $R = [0, 3] \times [0, 3]$ . Use a Riemann sum with nine terms to estimate the value of  $\iint_R f(x, y) dA$ . Take the sample points to be the upper right corners of the squares.

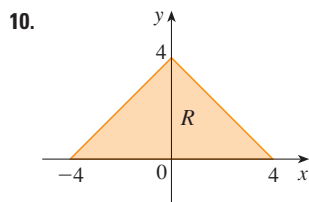
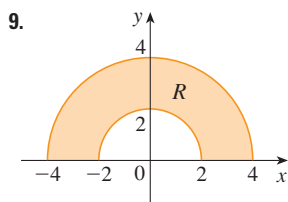


2. Use the Midpoint Rule to estimate the integral in Exercise 1.

3–8 Calculate the iterated integral.

3.  $\int_1^2 \int_0^2 (y + 2xe^y) dx dy$       4.  $\int_0^1 \int_0^1 ye^{xy} dx dy$   
 5.  $\int_0^1 \int_0^x \cos(x^2) dy dx$       6.  $\int_0^1 \int_x^{e^x} 3xy^2 dy dx$   
 7.  $\int_0^\pi \int_0^1 \int_0^{\sqrt{1-y^2}} y \sin x dz dy dx$       8.  $\int_0^1 \int_0^y \int_x^1 6xyz dz dx dy$

9–10 Write  $\iint_R f(x, y) dA$  as an iterated integral, where  $R$  is the region shown and  $f$  is an arbitrary continuous function on  $R$ .



11. Describe the region whose area is given by the integral

$$\int_0^{\pi/2} \int_0^{\sin 2\theta} r dr d\theta$$

12. Describe the solid whose volume is given by the integral

$$\int_0^{\pi/2} \int_0^{\pi/2} \int_1^2 \rho^2 \sin \phi d\rho d\phi d\theta$$

and evaluate the integral.

13–14 Calculate the iterated integral by first reversing the order of integration.

13.  $\int_0^1 \int_x^1 \cos(y^2) dy dx$       14.  $\int_0^1 \int_{\sqrt{y}}^1 \frac{ye^{x^2}}{x^3} dx dy$

15–28 Calculate the value of the multiple integral.

15.  $\iint_R ye^{xy} dA$ , where  $R = \{(x, y) \mid 0 \leq x \leq 2, 0 \leq y \leq 3\}$   
 16.  $\iint_D xy dA$ , where  $D = \{(x, y) \mid 0 \leq y \leq 1, y^2 \leq x \leq y + 2\}$   
 17.  $\iint_D \frac{y}{1+x^2} dA$ , where  $D$  is bounded by  $y = \sqrt{x}$ ,  $y = 0$ ,  $x = 1$   
 18.  $\iint_D \frac{1}{1+x^2} dA$ , where  $D$  is the triangular region with vertices  $(0, 0)$ ,  $(1, 1)$ , and  $(0, 1)$   
 19.  $\iint_D y dA$ , where  $D$  is the region in the first quadrant bounded by the parabolas  $x = y^2$  and  $x = 8 - y^2$   
 20.  $\iint_D y dA$ , where  $D$  is the region in the first quadrant that lies above the hyperbola  $xy = 1$  and the line  $y = x$  and below the line  $y = 2$   
 21.  $\iint_D (x^2 + y^2)^{3/2} dA$ , where  $D$  is the region in the first quadrant bounded by the lines  $y = 0$  and  $y = \sqrt{3}x$  and the circle  $x^2 + y^2 = 9$   
 22.  $\iint_D x dA$ , where  $D$  is the region in the first quadrant that lies between the circles  $x^2 + y^2 = 1$  and  $x^2 + y^2 = 2$   
 23.  $\iiint_E xy dV$ , where  $E = \{(x, y, z) \mid 0 \leq x \leq 3, 0 \leq y \leq x, 0 \leq z \leq x + y\}$   
 24.  $\iiint_T xy dV$ , where  $T$  is the solid tetrahedron with vertices  $(0, 0, 0)$ ,  $(\frac{1}{3}, 0, 0)$ ,  $(0, 1, 0)$ , and  $(0, 0, 1)$   
 25.  $\iiint_E y^2 z^2 dV$ , where  $E$  is bounded by the paraboloid  $x = 1 - y^2 - z^2$  and the plane  $x = 0$

26.  $\iiint_E z \, dV$ , where  $E$  is bounded by the planes  $y = 0$ ,  $z = 0$ ,  $x + y = 2$  and the cylinder  $y^2 + z^2 = 1$  in the first octant
27.  $\iiint_E yz \, dV$ , where  $E$  lies above the plane  $z = 0$ , below the plane  $z = y$ , and inside the cylinder  $x^2 + y^2 = 4$
28.  $\iiint_H z^3 \sqrt{x^2 + y^2 + z^2} \, dV$ , where  $H$  is the solid hemisphere that lies above the  $xy$ -plane and has center the origin and radius 1

29–34 Find the volume of the given solid.

29. Under the paraboloid  $z = x^2 + 4y^2$  and above the rectangle  $R = [0, 2] \times [1, 4]$
30. Under the surface  $z = x^2 y$  and above the triangle in the  $xy$ -plane with vertices  $(1, 0)$ ,  $(2, 1)$ , and  $(4, 0)$
31. The solid tetrahedron with vertices  $(0, 0, 0)$ ,  $(0, 0, 1)$ ,  $(0, 2, 0)$ , and  $(2, 2, 0)$
32. Bounded by the cylinder  $x^2 + y^2 = 4$  and the planes  $z = 0$  and  $y + z = 3$
33. One of the wedges cut from the cylinder  $x^2 + 9y^2 = a^2$  by the planes  $z = 0$  and  $z = mx$
34. Above the paraboloid  $z = x^2 + y^2$  and below the half-cone  $z = \sqrt{x^2 + y^2}$
- 
35. Consider a lamina that occupies the region  $D$  bounded by the parabola  $x = 1 - y^2$  and the coordinate axes in the first quadrant with density function  $\rho(x, y) = y$ .
- Find the mass of the lamina.
  - Find the center of mass.
  - Find the moments of inertia and radii of gyration about the  $x$ - and  $y$ -axes.
36. A lamina occupies the part of the disk  $x^2 + y^2 \leq a^2$  that lies in the first quadrant.
- Find the centroid of the lamina.
  - Find the center of mass of the lamina if the density function is  $\rho(x, y) = xy^2$ .
37. (a) Find the centroid of a right circular cone with height  $h$  and base radius  $a$ . (Place the cone so that its base is in the  $xy$ -plane with center the origin and its axis along the positive  $z$ -axis.)
- (b) Find the moment of inertia of the cone about its axis (the  $z$ -axis).
38. Find the area of the part of the cone  $z^2 = a^2(x^2 + y^2)$  between the planes  $z = 1$  and  $z = 2$ .
39. Find the area of the part of the surface  $z = x^2 + y$  that lies above the triangle with vertices  $(0, 0)$ ,  $(1, 0)$ , and  $(0, 2)$ .


- CAS** 40. Graph the surface  $z = x \sin y$ ,  $-3 \leq x \leq 3$ ,  $-\pi \leq y \leq \pi$ , and find its surface area correct to four decimal places.

41. Use polar coordinates to evaluate

$$\int_0^3 \int_{-\sqrt{9-x^2}}^{\sqrt{9-x^2}} (x^3 + xy^2) \, dy \, dx$$

42. Use spherical coordinates to evaluate

$$\int_{-2}^2 \int_0^{\sqrt{4-y^2}} \int_{-\sqrt{4-x^2-y^2}}^{\sqrt{4-x^2-y^2}} y^2 \sqrt{x^2 + y^2 + z^2} \, dz \, dx \, dy$$

-  43. If  $D$  is the region bounded by the curves  $y = 1 - x^2$  and  $y = e^x$ , find the approximate value of the integral  $\iint_D y^2 \, dA$ . (Use a graphing device to estimate the points of intersection of the curves.)

- CAS** 44. Find the center of mass of the solid tetrahedron with vertices  $(0, 0, 0)$ ,  $(1, 0, 0)$ ,  $(0, 2, 0)$ ,  $(0, 0, 3)$  and density function  $\rho(x, y, z) = x^2 + y^2 + z^2$ .

45. The joint density function for random variables  $X$  and  $Y$  is

$$f(x, y) = \begin{cases} C(x + y) & \text{if } 0 \leq x \leq 3, 0 \leq y \leq 2 \\ 0 & \text{otherwise} \end{cases}$$

- (a) Find the value of the constant  $C$ .

- (b) Find  $P(X \leq 2, Y \geq 1)$ .

- (c) Find  $P(X + Y \leq 1)$ .

46. A lamp has three bulbs, each of a type with average lifetime 800 hours. If we model the probability of failure of the bulbs by an exponential density function with mean 800, find the probability that all three bulbs fail within a total of 1000 hours.

47. Rewrite the integral

$$\int_{-1}^1 \int_{x^2}^1 \int_0^{1-y} f(x, y, z) \, dz \, dy \, dx$$

as an iterated integral in the order  $dx \, dy \, dz$ .

48. Give five other iterated integrals that are equal to

$$\int_0^2 \int_0^{y^3} \int_0^{y^2} f(x, y, z) \, dz \, dx \, dy$$

49. Use the transformation  $u = x - y$ ,  $v = x + y$  to evaluate

$$\iint_R \frac{x - y}{x + y} \, dA$$

where  $R$  is the square with vertices  $(0, 2)$ ,  $(1, 1)$ ,  $(2, 2)$ , and  $(1, 3)$ .

50. Use the transformation  $x = u^2$ ,  $y = v^2$ ,  $z = w^2$  to find the volume of the region bounded by the surface  $\sqrt{x} + \sqrt{y} + \sqrt{z} = 1$  and the coordinate planes.

51. Use the change of variables formula and an appropriate transformation to evaluate  $\iint_R xy \, dA$ , where  $R$  is the square with vertices  $(0, 0)$ ,  $(1, 1)$ ,  $(2, 0)$ , and  $(1, -1)$ .

52. The **Mean Value Theorem for double integrals** says that if  $f$  is a continuous function on a plane region  $D$  that is of type I or II, then there exists a point  $(x_0, y_0)$  in  $D$  such that

$$\iint_D f(x, y) \, dA = f(x_0, y_0)A(D)$$

Use the Extreme Value Theorem (14.7.8) and Property 15.3.11 of integrals to prove this theorem. (Use the proof of the single-variable version in Section 6.5 as a guide.)

53. Suppose that  $f$  is continuous on a disk that contains the point  $(a, b)$ . Let  $D_r$  be the closed disk with center  $(a, b)$  and radius  $r$ . Use the Mean Value Theorem for double integrals (see

Exercise 52) to show that

$$\lim_{r \rightarrow 0} \frac{1}{\pi r^2} \iint_{D_r} f(x, y) \, dA = f(a, b)$$

54. (a) Evaluate  $\iint_D \frac{1}{(x^2 + y^2)^{n/2}} \, dA$ , where  $n$  is an integer and  $D$  is

the region bounded by the circles with center the origin and radii  $r$  and  $R$ ,  $0 < r < R$ .

(b) For what values of  $n$  does the integral in part (a) have a limit as  $r \rightarrow 0^+$ ?

(c) Find  $\iiint_E \frac{1}{(x^2 + y^2 + z^2)^{n/2}} \, dV$ , where  $E$  is the region

bounded by the spheres with center the origin and radii  $r$  and  $R$ ,  $0 < r < R$ .

(d) For what values of  $n$  does the integral in part (c) have a limit as  $r \rightarrow 0^+$ ?